

CAT-300

Repeater Controller

Computer Automation Technology, Inc.

4631 N.W. 31st Avenue, Suite 142
Fort Lauderdale, Florida 33309
Phone: (954) 978-6171 Fax: (561) 488-2894
Internet: <http://www.catauto.com>

Table of Contents

<u>Chapter</u>		<u>Page</u>
1.	Introduction and Specifications	1-1
2.	System Configuration	2-1
3.	Repeater Control (DTMF)	3-1
4.	Repeater Operation	4-1
5.	Repeater Programming (DTMF)	5-1
6.	Interfacing to Other Equipment	6-1
7.	Voice Synthesizer Vocabulary	7-1
8.	Drawings	8-1
9.	Schematics	9-1
10.	Parts List	10-1
11.	CI-300 Computer Interface	11-1
12.	DL-1000C Audio Delay	12-1
13.	DR-1000 Digital Voice Recorder	13-1

REVISED 06/10/03

Foreword

For your convenience, this manual is divided into twelve chapters. A brief description of each chapter and its contents are listed below. Control and programming of the CAT-300 has been carefully structured. Once you become familiar with the procedures described in this manual, you will find it easy to program and control the CAT-300 to suite your particular requirements.

- Chapter 1 This chapter describes some of the CAT-300 features. Also included are the technical specifications.
- Chapter 2 This chapter describes the various configurations for the CAT-300, dip-switch settings and modes of operation.
- Chapter 3 This chapter describes how to control the CAT-300. The control operator prefix code must precede each control command. The default value for the control operator code is [100]. **Do not unlock the CAT-300 when changing control channels.**
- Chapter 4 This chapter describes how to use the features of the CAT-300. These are considered repeater user commands.
- Chapter 5 This chapter describes how to program the CAT-300 with DTMF tones. **During programming the CAT-300 must be un-locked.** The default value for the unlock code is [1234567].
- Chapter 6 This chapter describes how to interface the CAT-300 to a RF package. It defines the input - output connections and how to adjust the audio levels.
- Chapter 7 This chapter contains a list of the vocabulary words used to program the voice synthesizer.
- Chapter 8 This chapter contains PC board layouts for part location on the CAT-300, DL-100C and DR-1000 boards.
- Chapter 9 This chapter contains the schematics diagram (1) sheet for the CAT-300, (1) sheet for the DL-1000C and 1 sheet for the DR-1000.
- Chapter 10 This chapter contains a part list for the CAT-300, DL-1000C and DR-1000 printed circuit boards.
- Chapter 11 This chapter describes how to connect a computer to the CAT-300 controller using the optional CI-300 Computer Interface. Information includes a description of the editor program and how to upload and download the contents of memory.
- Chapter 12 This chapter describes how to connect the DL-1000C Audio Delay board to the CAT-300 Controller.
- Chapter 13 This chapter describes how to connect the DR-1000 Digital Voice Recorder to the CAT-300 Controller.

Chapter 1 - Introduction and Specifications

Congratulations on your purchase of the CAT-300 Repeater Controller. The CAT-300 is packed with features normally reserved for controllers costing thousands of dollars more. Built on the foundation of the very successful CAT-1000, this controller incorporates the features suggested by customers like you.

Programming the CAT-300 is a snap. It is carefully structured with uniform programming commands throughout. The manual is easy to follow with numerous examples. The voice synthesizer interacts with you during each control and programming operation. Some of these features are described in the following text.

CAT-300 [DX]

The CAT-300 is available in a deluxe version known as the CAT-300DX. The deluxe version contains a digital clock and additional memory. This permits time of day announcements, scheduler activity, macros, telephone area code and prefix number look-up tables, adds four memory saves and increases the speed dial memory locations from twenty-five to one-hundred.

Scheduler [DX]

An advanced 40-position scheduler fully automates repeater operation. Any command that can be manually executed can also be scheduled to one-minute accuracy. Program the hours, minutes, day of week, or day of month and month of year. The CAT-300 will do the rest.

Voice Synthesizer

A vocabulary base of 422 words carefully selected for amateur repeater operation are available to ID your repeater, announce the time and interact with you during control and programming operations. Additional message buffers can be activated on demand, through hardware inputs or by the scheduler.

Digital Voice Clock [DX]

The digital voice clock will announce the time upon request, at the completion of an autopatch, during repeater IDs, or on the hour through the grandfather clock feature.

Autopatch

A full feature autopatch with storage for [25] or [100] speed dial numbers highlight the CAT-300. Each speed dial location accepts numbers of up to eleven digits and includes space for the users call letters. Regular calls are preceded by a phone number read-back. This feature can be suppressed by a mic key-click. Hook-Flash and autopatch time extender commands round out the features. In addition to the Reverse autopatch, full telephone control and programming provides an extra measure of security. Long distance protection is provided by a number counter with a first number 0-1 check. A user programmable pre-dial number buffer is provided for [9] or [*67] caller ID suppression.

User Function Switches

Three user function output switches are provided to control equipment at your repeater site. These switches can be controlled manually by DTMF commands, or by the scheduler during automatic operation. They can be made to turn OFF, ON or Momentarily change state, any time you choose.

Hardware Inputs

Two hardware inputs activated by an input from other equipment at the repeater site, causes the CAT-300 to execute any repeater command. External repeater control or information about the repeater site will be instantly available.

Courtesy Tone

Memory space is provided for the storage of eight custom courtesy tones. Each tone can consist of up to three different tone frequencies of various lengths and separations.

Digital Voice Recorder

An optional DVR, controlled by the CAT-300 can be added to your repeater. Control of the DVR is fully integrated into the CAT-300 control and command structure. The CAT-300 will permit you to substitute any of the sixteen DVR tracks in place of the messages normally generated by the voice synthesizer. In fact: you can even intermix DVR tracks with voice synthesizer messages. A signal report test is also included. Enter a DTMF command to record a seven second test message. Un-key and the test message will playback. You instantly know how your signal sounds through the repeater.

CW ID

The repeater will switch to a CW ID when a repeater user talks over the voice ID.

Repeater Control Prefix

A total of fourteen prefix numbers control repeater operation. Each prefix is programmable from one to seven digits depending on the security you require.

Repeater Timers

A total of sixteen timers control repeater operation. Each timer is user programmable to afford maximum flexibility to suite your special requirements.

DTMF Keypad Test

A DTMF keypad test will read back the numbers decoded in a synthesized voice.

Macro [DX]

By entering a single macro number, the CAT-300 will execute up to five commands in a string. Memory space is provided for the storage of ten macro strings. This feature permits the repeater owner to customize the control functions to suit his or her particular needs.

Active Memory Save [DX]

Configure the CAT-300 to suite your special requirements. Active Memory Save permits you to store the current settings of the control channels, timers, codes, CW ID buffer and the twelve voice messages. Memory space is provided for the storage of four memory saves. These memory saves can be later recalled with a simple DTMF command.

Specifications

Microprocessor	80C535
Memory	EPROM 64K X 8 RAM 2K X 8 (non volatile) 8K X 8 (non volatile) [DX]
Clock Accuracy [DX]	+1 minute per month at +25 degrees C. In the absence of power, data and time will be maintained for ten years.
Voice Synthesizer	Texas Instruments TSP53C30 Linear Predictive Coded
Voice Vocabulary	422 Words
DTMF Transceiver	Mitel MT8880
Operating Temperature	-15 to +55 degrees C
Call Letter ID	Buffer size Voice (23) CW (31)
Control Codes	(14) Buffer size (1 - 7) Digits
Scheduler [DX]	(40) Commands
Macro [DX]	(10) Five Function
Memory Saves [DX]	(4) Control, Timers, Codes, CW ID, (12) Voice Messages
Speed Dial (User)	(25) Eleven Digit Entry - Eight Position ID
Speed Dial (User) [DX]	(100) Eleven Digit Entry - Eight Position ID
Speed Dial (Emergency)	(5) Eleven Digit Entry - Eight Position ID
Telephone Area Code [DX]	(10) Area Code Look-up Table - Ten Position
Telephone Prefix Number [DX]	(100) Prefix Look-up Table - Hundred Position
Voice Synthesizer	(12) Messages Maximum Word Length (23)
Digital Voice Recorder	(16) Tracks Maximum Record Time (2 minutes)
User Function Outputs	(3) Switch Open Collector Relay Driver 40 volts at 80 ma.
Hardware Inputs	(2) 10K ohm input impedance

Audio Input Receiver	0.2 - 2VAC adjustable 10K ohms
Audio Output Transmitter	2 VAC adjustable 600 ohms
Logic Inputs Active Low	0 to .8 volts
Logic Inputs Active High	2.4 to 15 volts
Part 68 Telephone Certification	(4H1USA-21625-KX-E) (REN - 0.4B)
Power Requirements	9 to 15 VDC MAX input at 80 mA
Size	7.0" X 6.0"

Warranty

Computer Automation Technology warrants this product to the original purchaser to be free from defective materials and workmanship for a period of one (1) year from the date of purchase when returned prepaid. Computer Automation Technology shall not be liable for any consequential damages caused by this product.

Software Copyright

The software in this product is copyrighted by and remains the property of Computer Automation Technology Inc. Reproduction, duplication, or disclosure is not permitted without prior written consent of Computer Automation Technology Inc. This manual may be reproduced without prior written consent if the copies are distributed free of charge.

FCC Part 68 Equipment Registration

Should the CAT-300 controller or its protective circuitry cause harm to the telephone network, the telephone company shall, where practical, notify you that temporary discontinuance of service may be required. However, where prior notices are not practical, the telephone company may temporarily discontinue service if such action is deemed reasonable in the circumstances. In the case of such temporary discontinuance, the telephone company shall promptly notify you. You have the right to bring a complaint to the FCC if you feel the disconnection is not warranted.

The telephone company may make changes in its communications facilities, equipment, operation or procedures, where such action is reasonably required and proper in its business. Should any such changes render the CAT-300 incompatible with the telephone company facilities you shall be given adequate notice to make modifications to maintain service.

The FCC prohibits the connection of the CAT-300 controller to party lines or to be used in conjunction with coin telephone service.

The CAT-300 is equipped with a USOC RJ11C standard miniature modular jack and is designed to have the telephone line connected with the standard plug. If the plug is withdrawn, no interference to other equipment connect to the same line will be encountered.

Telephone company notification prior to connection of the CAT-300 controller is no longer required. However, if requested by the telephone company you must provide the registration number: (4H1USA-21625-KX-E), ringer equivalency number: (REN 0.4B) and the line to which the CAT-300 controller is connected.

In the event the CAT-300 should fail to operate properly, disconnect it from the telephone line until the controller is repaired. If service is needed contact:

Computer Automation Technology Inc.
4631 N.W. 31st. Avenue Suite 142
Fort Lauderdale, Fl. 33309
Phone: VOICE (954) 978-6171 - FAX (561) 488-2894
Internet: <http://www.catauto.com>

FCC Part 15 RF Interference

When installed in the RME-1000 rack mount enclosure, the CAT-300 has been tested and found to meet the standards for a Class A digital device, as specified in Part 15 of the FCC Rules. These specifications are designed to provide reasonable protection against such interference in a commercial installation. However, there is no guarantee that interference will not occur in a particular installation.

Chapter 2 - System Configuration

Repeater With Digital Voice Recorder

In this configuration the CAT-300 supports a repeater with a CTCSS decoder and the optional DVR-1000 Digital Voice Recorder.

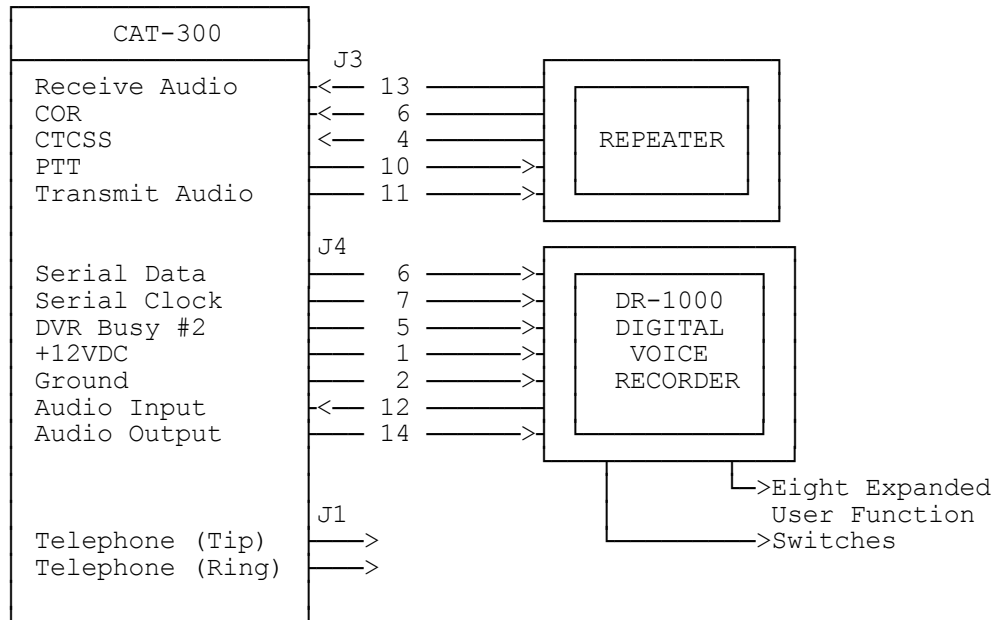

Figure 2-1

Modular telephone jack J1, provides connection to the telephone line.

Dip Switch Settings

A eight position dip switch is used to configure the CAT-300.

Switch 1

This switch determines Repeater COR input logic. Switch #1 should be ON if the repeater receiver's COR is an active low and OFF if COR is active high.

Switch 2

This switch determines CTCSS input logic. Switch #2 should be ON if the CTCSS input is an active low and OFF if the CTCSS is active high.

Switch 3

This switch determines User Function Switch #1 input logic. Dipswitch #3 should be ON if the User Function Switch #1 input is an active low and OFF if User Function Switch #1 is an active high.

Switch 4

This switch determines User Function Switch #2 input logic. Dip-switch #4 should be ON if the User Function Switch #2 input is an active low and OFF if User Function Switch #2 is an active high.

Switch 5

This switch is used to configure a section of the CAT-300DX extended memory. If dipswitch #5 is OFF this area is assigned as the forth memory save. If dipswitch #5 is ON this area is assigned as look-up tables for [10] area codes and [100] telephone prefix numbers. To configure the memory as look-up tables this switch must be ON prior to initializing the CAT-300DX with dipswitch #7. During an upgrade, to prevent loss of the program, perform an erase command on the two area code and twenty prefix number table positions.

Switch 6

This switch is used to determine the type of dialing during an autopatch. If dip-switch #6 is OFF, the CAT-300 will dial with DTMF tones. If dipswitch #6 is ON, the CAT-300 will pulse dial at a 10 pulse per second rate. To increase the rate to 20 pulses per second, set control channel Zone 5 Channel 7 to ON.

Switch 7

This switch is used to initialize the CAT-300. Set this switch to ON. Cycle the power OFF and back ON. During power-up, the memory will be flushed and reloaded with default values. The voice will say: "RESET DATA LOAD COMPLETED." Set switch #7 to the OFF position.

Switch 8

This switch is used to program a new unlock number. Set switch #8 to ON. The voice will say: "ENTER CONTROL." After the seven digit unlock number is entered, set switch #8 to the OFF position. Switch #8 is also used to activate the computer interface. See chapter 14. Turn the DC power off. Set switch #8 to ON and turn the DC power ON. After the power-up message is complete, the CAT-300DX will switch to the computer interface mode.

Chapter 3 - Repeater Control

The CAT-300 has a maximum capacity of 64 remote control channels. These channels are segregated into eight zones according to their function. In addition to being controlled by the scheduler, these channels can be manually controlled by DTMF commands on the repeater, or telephone inputs.

Interrogation of Repeater Control Status by Radio

Key-up and send the control operator prefix number followed by the zone number and a zero. Un-key and the voice synthesizer will read back the channels that are turned on in that zone. Example: "ONE TWO FIVE ON." If all the channels are turned off, the voice synthesizer will say: "ALL CLEAR."

Changing Repeater Control Status by Radio

To change the status of a channel, key-up and send the control operator prefix number followed by the zone number, channel number and a [1] to turn the channel ON or a [0] to turn the channel OFF. Un-key and the voice will read back the zone, channel number and control activity. The voice will say: "ONE ONE ON." or "THREE FIVE OFF." Example: With a control operator prefix of 100, turn Zone 3 Channel 5 ON

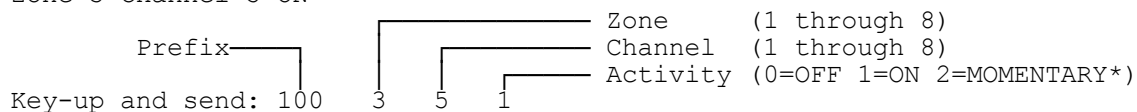

Un-key and the voice synthesizer will say: "THREE FIVE ON."

* The momentary command is limited to Zone 6, Channels 6, 7 and 8.

Changing Repeater Control Status By Telephone

Call the repeater by telephone. When the CAT-300 answers a beep will be heard. Enter the control operator prefix code followed by a (#) pound. The voice will say: "CONTROL READY." You need only enter the Zone number, Channel number and a (1) to turn the channel ON or a (0) to turn the channel OFF followed by the (#) pound. It is not necessary to enter the control operator prefix number before each command when controlling by phone. To terminate control send [*0#].

Repeater Control Channels

Zone 1

1. Repeater Transmitter	Enable *
2. Repeater CTCSS	Enable
3. DTMF Access	Enable
4. Repeater CTCSS Override	Enable
5. Turn on Delay	Enable
6. DTMF Window	Enable
7. DTMF Muting	Enable
8. Control Operator CTCSS	Enable

Zone 2

1. Repeater Timeout Timer	Enable*
2. Squelch Tail	Enable*
3. Scheduler [DX]	Enable*
4. DTMF Pad Test	Enable*
5. Repeater CTCSS OR Logic	Enable
6. Grandfather Clock Sleep [DX]	Enable
7. Courtesy Beep	Enable*
8. Talk Over Voice Synthesizer	Enable

Zone 3

1. Repeater ID #1 (At Rest)	Enable *
2. Repeater ID #2 (Active)	Enable *
3. Squelch Tail Message	Enable
4. Dropout Message	Enable
5. Reserved	Enable
6. Reserved	Enable
7. Time of Day Request [DX]	Enable *
8. Grandfather Clock [DX]	Enable *

Zone 4

1. Autopatch	Enable*
2. Autopatch Timeout Timer	Enable*
3. Long Distance	Enable
4. Emergency 911	Enable*
5. User Speed Dial	Enable*
6. Phone Number Read Back	Enable*
7. Autopatch Radio Mute	Enable
8. Autopatch Pre-Dial	Enable

Zone 5

1. Emergency Speed Dial	Enable *
2. Reverse Autopatch	Enable *
3. Long Distance Dial (1)	Enable
4. Telephone Off Hook	Enable
5. Remote Autopatch	Enable
6. Telephone Line Busy	Enable
7. Dial Rate (20 P.P.S.)	Enable
8. Ring Detector	Enable *

Zone 6

1. Remote Base Transmit	Enable
2. Remote Base Receive Only	Enable
3. Reserved	Enable
4. User Function Switch In #1	Enable*
5. User Function Switch In #2	Enable*
6. User Function Switch Out #1	Enable
7. User Function Switch Out #2	Enable
8. User Function Switch Out #3	Enable

Zone 7

1. Expanded UF Output #1	Enable
2. Expanded UF Output #2	Enable
3. Expanded UF Output #3	Enable
4. Expanded UF Output #4	Enable
5. Expanded UF Output #5	Enable
6. Expanded UF Output #6	Enable
7. Expanded UF Output #7	Enable
8. Expanded UF Output #8	Enable

Zone 8

1. Autopatch CTCSS	Enable
2. Area Code Look-Up [DX]	Enable
3. Prefix Number Look-Up [DX]	Enable
4. Speed Dial Pre-Dial	Enable
5. Telephone Ring Announcer	Enable
6. Reserved	Enable
7. Reserved	Enable
8. Reserved	Enable

* During initialization these control channels are set to the enable position.

Zone 1 Repeater Control

1. Repeater Transmitter Enable

This is the master repeater switch. This channel must be enabled for normal repeater operation. The CAT-300 will continue to respond to control operator commands even when the repeater's transmitter is disabled. This channel will automatically be enabled after an initialization reset.

2. Repeater CTCSS Enable

When this channel is enabled, in addition to a COR input, an input from a CTCSS decoder at J3-4 must also be present before the repeater will activate. A COR input by itself will have no affect. To prevent loss of control, **DO NOT ENABLE THIS CHANNEL** unless a CTCSS decoder is connected to J3-4.

3. DTMF Access Enable

When this channel is enabled, a DTMF Access number selected by programming command *504* must be entered to activate the repeater. Once this number is entered and the user un-keys, the voice will say: "OK UP". A COR input will activate the repeater until it returns to rest. A rest period of up to 29 minutes can be selected with the [*602*] programming command. When the CAT-300 is initialized this timer defaults to 60 seconds. This timer can be bypassed returning the repeater to DTMF Access by sending the DTMF Access number. The voice will say: "OK DOWN".

4. Repeater CTCSS Override

When this channel is enabled, and CTCSS is also enabled, a repeater user without a CTCSS encoder can activate the repeater by entering the DTMF Access number. Once this number is entered and the user un-keys, the voice will say: "OK UP". A COR input will activate the repeater until it returns to rest.

5. Turn on Delay Enable

When this channel is enabled, a deliberate and sustained input must be present before the controller will activate the repeater. A time delay of 0.1 to 9.9 seconds can be selected with the [*603*] programming command. When the CAT-300 is initialized, this timer defaults to 1.0 seconds. This channel is useful during periods when noise bursts are present on the repeater input.

6. DTMF Window

When this channel is enabled the controller will only accept DTMF entries when the window is open. The pre-window timer programming command [*613*] sets the time the window opens after the presents of COR. The length of the time the window remains open is set by the window timer programming command [*614*]. When the CAT-300 is initialized the pre-window timer defaults to 2 seconds and the window timer defaults to 8 seconds. Therefore the CAT-300 will only accept DTMF entries from 2 to 10 seconds after initial COR.

7. DTMF Muting Enable

When this channel is enabled, anytime a DTMF tone is received the audio will be turned off to the repeater's transmitter. The transmit audio will remain muted until a pre-determined time after the last DTMF tone is received. This time is set by the [*606*] timer programming command. During the mute period, cover beeps are transmitted each second to indicate repeater activity. This feature prevents control commands from being repeated. It provides a extra measure of security. There may be times when it is desirable to pass the DTMF tones through the repeater. To temporarily disable DTMF muting, precede the DTMF string with a pound (#).

8. Control Operator CTCSS Enable

When this channel is enabled, a CTCSS input is required for the CAT-300 to accept control or program inputs from the control operator.

Zone 2 Repeater Control

1. Repeater Timer Enable

Repeater timeout is user programmable with the [*601*] timer programming command. When the CAT-300 is initialized, this timer defaults to 3 minutes. When this channel is turned off, the repeater will not time-out.

2. Squelch Tail Enable

When this channel is enabled, the repeater's transmitter will remain on for a period of time determined by the COR Drop to Courtesy Beep Timer [*604*] and Courtesy Beep to PTT Drop Timer [*605*]. To make the transmitter turn off the instant COR is lost, turn this channel OFF. This feature is useful when linking to other repeaters or during band openings.

3. Scheduler Enable

When this channel is enabled, all action by the scheduler will be executed per the times programmed in the scheduler table. There may be times, during emergency net operations, when it is not desirable to have channels change automatically. To suspend scheduler operation, turn this channel off.

4. DTMF Pad Test Enable

When this channel is enabled, a repeater user is able to perform a test of their radio's 12 or 16-button key-pad. As the numbers are being decoded, they are stored in memory. When the repeater user stops transmitting the controller will read back all the numbers that were decoded. **Do not use the [D] key during a pad test.**

5. Repeater CTCSS OR Logic Enable

When this channel is enabled, the COR and CTCSS inputs will function as a (OR) logic input. This means activity on either the COR or CTCSS inputs will cause the controller to key the repeater's transmitter. This is a layered command. Therefore, Repeater CTCSS Enable, Zone 1 Channel 2 must be ON or this control function will have no effect.

6. Grandfather Clock Sleep Enable [DX]

It may be desirable to suspend the grandfather clock operation during the early morning hours. When this channel is enabled, the last announcement will be at 11:00 PM. Time announcements will resume at 7:00 AM the next morning.

7. Courtesy Tone Enable

When this channel is enabled, a courtesy tone will occur when the COR signal is lost. To eliminate the courtesy tone, turn this channel OFF. The timeout timer will continue to be reset.

8. Talk Over Voice Synthesizer Enable

When this channel is enabled, Squelch Tail and Transmitter Drop messages will be mixed with receive audio. When this channel is disabled, receiver audio will be blocked when the voice synthesizer speaks.

Zone 3 Voice Synthesizer Control

1. Repeater ID #1 (At Rest) Enable

When this channel is enabled, repeater ID message #1 will repeat subject to the setting of the Repeater ID Timer [*607*]. This ID will consist of up to 23 words selected from the voice vocabulary table and programmed with the [*3101] command.

2. Repeater ID #2 (Active) Enable

When this channel is enabled, repeater ID message #2 will repeat subject to the setting of the ID timer. This ID will consist of up to 23 words selected from the voice vocabulary table and programmed with the [*3102] command. When Repeater ID #1 and #2 are enabled, ID messages selection will be determined by whether the repeater is at rest or active with a QSO in progress.

3. Squelch Tail Message Enable

When this channel is enabled, a voice squelch tail message will occur when a repeater user un-keys their transmitter. This message will repeat subject to the setting of the squelch tail message timer [*608*]. This message will consist of up to 23 words selected from the voice vocabulary table and programmed with the [*3103] command.

4. Dropout Message Enable

When this channel is enabled, a voice drop out message will occur just before the repeater transmitter turns off. This message will repeat subject to the setting of the drop out message timer [*609*]. This message will consist of up to 23 words selected from the voice vocabulary table and programmed with the [*3104] command.

5. Reserved

6. Reserved

7. Time of Day Request Enable [DX]

When this channel is enabled, repeater users can request a time of day announcement by entering the time of day request number. This message will consist of up to 23 words selected from the voice vocabulary table and is programmed with the [*3109] command. When the CAT-300 is initialized, this message defaults to: "THE TIME IS [ACTUAL TIME]."

8. Grandfather Clock Enable [DX]

When this channel is enabled, the CAT-300 will announce the time on the hour. This message will consist of up to 23 words selected from the voice synthesizer vocabulary table and programmed with the [*3110] command. When the CAT-300 is initialized, this message defaults to: "CAT-300 REPEATER THE TIME IS [ACTUAL TIME]."

Zone 4 Autopatch

1. Autopatch Enable

This channel must be enabled for the controller to process manually dialed autopatch requests.

2. Autopatch Timer Enable

Autopatch timeout is user programmable with the [*611*] and [*612*] timer programming commands. When the CAT-300 is initialized the autopatch timer defaults to 3 minutes and the autopatch activity timer defaults to 30 seconds. When this channel is turned off, the autopatch will not time-out.

3. Long Distance Enable

During autopatch dialing, the CAT-300 counts the total number of entries. Phone numbers in excess of eight digits will be considered a long distance call or an error in dialing. The controller will immediately terminate the autopatch. When this channel is enabled, phone numbers that have more than eight digits will be accepted.

4. Emergency 911 Enable

This channel must be enabled to process Emergency 911 requests. The controller examines all three-digit entries. When this channel is enabled, 911 calls will be permitted. The autopatch access code must precede 911.

5. User Speed Dial Enable

This channel must be enabled for the controller to process User Speed Dial requests. A user can access any speed dial location. The voice will say: "CALL TO W4XYZ", delay two seconds and then dial the phone number stored at that location. Space is provided for (25) or (100) phone numbers with call letter ID.

6. Phone Number Read Back Enable

This channel must be enabled for the controller to read-back the phone number prior to dialing. After the repeater user enters the number, the CAT-300 will read-back the number for verification. If the number was entered correctly, the repeater user does nothing and in two seconds the CAT-300 will redial the number. If the number is incorrect, the repeater user enters the autopatch disconnect code during the two second period and the call will be terminated. To temporarily suspend the phone number read back, key-up when the voice says: "AUTOPATCH".

7. Autopatch Radio Mute Enable

When this channel is enabled, during an autopatch, mobile radio audio will go directly to the telephone line and not be broadcast on the repeater's transmitter. A series of beeps will be heard on the repeater's output when the mobile is transmitting. This feature provides a measure of privacy during an autopatch.

8. Autopatch Pre-Dial Enable

When this channel is enabled the CAT-300 will generate the number stored in the pre-dial buffer," before regenerating the manually dial telephone number. This feature is useful when the CAT-300 is connected to a business phone system and a [9] is requires to access an outside line. This feature can also be used to suppress caller ID if the pre-dial buffer is loaded with [*67]. Use the [*89] programming command to enter a pre-dial number of up to seven digits. The default pre-dial number is [9].

Zone 5 Autopatch

1. Emergency Speed Dial Enable

Space is provided for five public service phone numbers with identifications. A user can access any emergency speed dial location. Example: the voice will say: "CALL TO FIRE DEPARTMENT," delay two seconds and then dial the phone number stored at that emergency speed dial location.

2. Reverse Autopatch Enable

This channel must be enabled for the controller to process a reverse autopatch.

A user can call the repeater by phone, enter the reverse autopatch prefix number followed by the speed dial table position number. Terminate the entry with the pound [#]. The controller will generate a ringing type tone and the voice will say: "CALL FOR W4XYZ." The radio user need only enter the reverse autopatch prefix number to complete the autopatch.

3. Long Distance Dial (1) Enable

When this channel is enabled, the CAT-300 will accept a (1) as the first entry of the telephone number even when Zone 4 Channel 3 "Long Distance Enable" is not turned ON. A (0) as the first entry will continue to be locked out.

4. Telephone Off Hook Enable

When this channel is enabled, the CAT-300 will take the phone off hook, key the repeater's transmitter and provide an audio path to manually dial a phone number.

5. Remote Autopatch Enable

When this channel is enabled, the controller will not respond to activity on the COR or COR+CTCSS inputs. The controller will respond to an autopatch, speed dial or reverse autopatch input. During this operation the controller will also respond to control and programming commands. All other inputs will be rejected.

6. Telephone Line Busy Enable

When this channel is enabled input #2 is converted to a telephone busy input. When this input is active an autopatch will be rejected and the voice will say: "TELEPHONE LINE IN SERVICE." Dipswitch #2 determines if the input is active high or low.

7. Dial Rate (20 P.P.S.) Enable

When this channel is enabled, and dipswitch #6 is on, the CAT-300 will dial the telephone at a rate of twenty pulses per second.

8. Ring Detector Enable

During control operator call-in, upon receipt of a ring detector input, the CAT-300 will simulate an off-hook condition. The delay in answering the phone is user programmable with the [*616*] programming command. When the CAT-300 is initialized, the ring detector timer defaults to 2 seconds. When this channel is turned off, the controller will not answer the phone. This feature is useful when more than one telephone device is sharing the same line.

Zone 6 User Function Control

1. Remote Base Transmit Enable

Although the CAT-300 was not intended to operate a remote base, it is relatively easy to add a transceiver if the RX audios are mixed external to the CAT-300 and the TX audio output is shared between the two transmitters. When this channel is enabled, Output #3 is converted to a transceiver PTT, while Input #1 becomes a transceiver COR input. Output #3 (PTT #2) will be active only when repeater COR is active. It will not be active when Input #1 (COR #2) is active. The transceiver must supply squelch switched audio.

2. Remote Base Receive Only Enable

If Zone 6 Channel 1 is enabled and this channel is also enabled, the remote base will be in the receive only mode. Any signals received by the remote base will be heard on the repeater's transmitter. However, conversations on the repeater will not be rebroadcast on the remote base transmitter.

3. Reserved

4. Input #1 Enable

When this channel is enabled, a voltage transition on J3 pin 1, determined by the setting of dip-switch #3, will execute the command stored at the Input #1 memory buffer.

5. Input #2 Enable

When this channel is enabled, a voltage transition on J3 pin 2, determined by the setting of dip-switch #4, will execute the command stored at the Input #2 memory buffer.

6. Output #1 Enable

When this channel is enabled, user function switch #1 is turned on. Connector J3 pin 7 will switch 28VDC and sink 150 MA. This feature provides remote control of other equipment at the repeater site.

7. Output #2 Enable

When this channel is enabled, user function switch #2 is turned on. Connector J3 pin 8 will switch 28 VDC and sink 150 MA.

8. Output #3 Enable

When this channel is enabled, user function switch #3 is turned on. Connector J3 pin 9 will switch 28 VDC and sink 150 MA.

Zone 7 Expanded User Function Switches

1. Expanded User Function Switch #1

MF-1000 Serial Interface Card switch #1 (J2 pin 24) will turn on when this channel is enabled.

2. Expanded User Function Switch #2

MF-1000 Serial Interface Card switch #2 (J2 pin 23) will turn on when this channel is enabled.

3. Expanded User Function Switch #3

MF-1000 Serial Interface Card switch #3 (J2 pin 22) will turn on when this channel is enabled.

4. Expanded User Function Switch #4

MF-1000 Serial Interface Card switch #4 (J2 pin 21) will turn on when this channel is enabled.

5. Expanded User Function Switch #5

MF-1000 Serial Interface Card switch #5 (J2 pin 20) will turn on when this channel is enabled.

6. Expanded User Function Switch #6

MF-1000 Serial Interface Card switch #6 (J2 pin 19) will turn on when this channel is enabled.

7. Expanded User Function Switch #7

MF-1000 Serial Interface Card switch #7 (J2 pin 18) will turn on when this channel is enabled.

8. Expanded User Function Switch #8

MF-1000 Serial Interface Card switch #8 (J2 pin 17) will turn on when this channel is enabled.

Zone 8

1. Autopatch CTCSS Enable

When this channel is enabled, a CTCSS input is required for the CAT-300 to accept an autopatch or speed dial request.

2. Area Code Look-Up Enable [DX]

If this channel is enabled along with Long Distance Enable (Zone 4 Channel 3), a ten or eleven digit telephone number will be compared to the area code look-up table. When a ten digit number is dialed the first, second and third numbers will be compared to the area code look-up table. When an eleven digit number is dialed the second, third and fourth numbers will be compared. If there is a match the autopatch will be permitted. No match and the autopatch will terminate. A telephone number other than ten or eleven digits will not be checked. This feature will not work if Long Distance Dial (1) Enable (Zone 5 Channel 3) is on.

3. Prefix Number Look-Up Enable [DX]

If this channel is enabled, a seven, eight, ten or eleven digit telephone number will be compared to the prefix number look-up table. When a seven digit number is dialed the first, second and third numbers will be compared to the prefix number look-up table. When an eight digit number is dialed the second, third and fourth numbers will be compared. When a ten digit number is dialed the fourth, fifth and sixth numbers will be compared to the prefix number look-up table. When an eleven digit number is dialed the fifth, sixth and seventh numbers will be compared. If there is a match the autopatch will be permitted. No match and the autopatch will terminate. A telephone number other than seven, eight, ten or eleven digits will not be checked.

4. Speed Dial Pre-Dial Enable

When this channel is enabled the CAT-300 will generate the number stored in the pre-dial buffer, before generating the telephone number stored in the speed dial memory. This feature is useful when the CAT-300 is connected to a business phone system and a [9] is required to access an outside line. This feature can also be used to suppress caller ID if the pre-dial buffer is loaded with [*67]. Use the [*89] programming command to enter a pre-dial number of up to seven digits. The default pre-dial number is [9].

5. Telephone Ring Announcer Enable

When this channel is enabled, the CAT-300 will key-up the transmitter and generate a ringing tone to indicate the repeater's phone is ringing.

Read Software Version

To read the current software version of the Program and Voice ROMs, key-up and enter the control operator prefix code followed by [98]. Un-key and the voice will read the software versions.

Soft Reset

To produce a soft reset, the equivalent of remotely cycling DC power, key-up and enter the control operator prefix code followed by [99]. Un-key and the microprocessor flags will be reset.

Load Memory Files By Telephone [DX]

In the control operator mode the CAT-300 will accept commands to read and load memory files by telephone. To read the current memory file enter [90#]. To load a memory file enter:

COMMAND	DESCRIPTION	COMMAND	DESCRIPTION
91#	Load memory file 1	93#	Load memory file 3
92#	Load memory file 2	94#	Load memory file 4

Figure 3-1

NOTE: Memory File 4 will be disabled if the CAT-300DX is configured to support an area code and prefix number look-up table.

Chapter 4 - Repeater Operation

Time of Day Request [DX]

Key-up, and enter the time of day access code. Un-key, and the voice synthesizer will announce the time. Example: The voice will say: "THE TIME IS 7:30 PM". The time of day announcement is stored in voice message buffer [09] and can be changed with the [*3109] programming command.

DTMF Keypad Test

Key-up, and enter the DTMF key-pad access code followed by the key-pad numbers and letters to be tested. The entries can be in any order. Un-key, and the voice will read-back all numbers and letters that were decoded including the "STAR" and "POUND". Note: The "D" key cannot be tested. See Forced DTMF Command Entry.

Forced DTMF Command Entry

During normal operation a DTMF command is entered at the drop of receiver COR. It is possible to force a DTMF command entry even while COR is present. The CAT-300 will accept the [D] key as an entry command.

DTMF Access

When the repeater is in the DTMF Access mode, you must enter the DTMF Access code to activate the repeater. The voice will say: "OK UP" and the repeater will respond to a carrier input. When the repeater returns to rest, for a time determined by the sleep timer, the DTMF Access code must be reentered to activate the repeater. You can bypass the rest period and return the repeater to DTMF access mode by reentering the DTMF access code. The voice will say: "OK DOWN."

Repeater CTCSS Override

When repeater CTCSS is enabled, a repeater user without a CTCSS encoder can activate the repeater by entering the DTMF Access number. The voice will say: "OK UP" and the repeater will respond to a carrier input. After the repeater returns to rest, the DTMF Access code must be re-entered to override the CTCSS requirement. You can bypass the rest period and return the repeater to DTMF access mode by reentering the DTMF access code. The voice will say: "OK DOWN."

Autopatch Access

To initiate an autopatch, key-up and enter the autopatch access code followed by the number. Un-key, and the CAT-300 will redial the number. A series of beeps will be generated to indicate dialing in progress. The autopatch code can be any number from one to seven digits and is user selectable with the [*507*] programming command. During initialization the access code defaults to a [*].

Autopatch Access With Phone Number Verification

Key-up, and enter the autopatch access code followed by the number. Un-key, and the voice will read back the number, wait two seconds and then dial the number. If the number is incorrect, enter the autopatch disconnect code during the two second period. This will terminate the autopatch and prevent a wrong number.

Autopatch Phone Number Read Back Suppression

To temporarily suppress the phone number read back, key-click your microphone when you hear the voice say: "AUTOPATCH". The CAT-300 will immediately start to dial the number.

Autopatch Speed Dial Access

Key-up, and enter the speed dial number. Un-key, and the voice will read back the call letters assigned to that speed dial location, wait two seconds and then dial the number. Speed dial capacity is (25) or (100) numbers. The speed dial code can be any number from one to seven digits and is user selectable with the [*509*] programming command. During initialization, the speed dial code default to [6]. The speed dial number consists of the speed dial code, and the two-digit table position 00 through 24 or 00 through 99.

Autopatch Emergency Speed Dial Access

Key-up, and enter the emergency speed dial number. Un-key, and the voice will read back the identification assigned to that emergency speed dial location, wait two seconds and then dial the number. The emergency speed dial code can be any number from one to seven digits and is user selectable with the [*510*] programming command. During initialization the emergency speed dial code defaults to [9]. The emergency speed dial number consists of the emergency speed dial code followed by the single digit table position 0 through 4.

Autopatch 911 Access

Key-up, and enter the autopatch access code followed by 911. Un-key, and the voice will say: "AUTOPATCH 911" wait two seconds and then dial the number.

Autopatch Termination

To terminate the autopatch key-up, enter the autopatch termination code. Un-key, the autopatch will terminate with a voice announcement. Example: "AUTOPATCH COMPLETED." The autopatch disconnect code can be any number from one to seven digits and is user selectable with the [*508*] programming command. During initialization the autopatch termination code defaults to a [#]. The autopatch termination message is stored in voice message buffer [8] and can be changed with the [*3108] programming command.

Reverse Autopatch

To initiate a reverse autopatch, call the repeater by telephone. When the CAT-300 answers the phone a beep will be heard. Enter the reverse autopatch code followed by the speed dial table position. You must terminate the entry with a (#) pound. The CAT-300 will turn on the repeater's transmitter, generate a ringing tone and say: "CALL FOR W4XYZ." To connect the reverse autopatch the radio operator must enter the reverse autopatch code.

Autopatch Timer Extend

If during an autopatch, you find additional time is needed, key-up and send the [*1]. This will reset the autopatch timer. The voice will say: "AUTOPATCH TIMER RESET."

Autopatch Hook-Flash

If your repeater's telephone line has "call waiting" service, you can intercept an incoming call. Key-up and send [*2], the CAT-300 will place the phone on hook for 200 milliseconds. This will signal the telephone company to switch the waiting call onto the repeater's phone line. Key-up and send [*2] to return to the original party.

Autopatch Radio Mute

During an autopatch if additional privacy is required, key-up and send [*3]. This will mute the radio side audio. For the remainder of the autopatch, cover tones will be sent when the mobile transmits.

Voice Message Selection

To play one of the twelve voice messages, key-up and enter the VOICE prefix number followed by the message number. The CAT-300 will key the transmitter and play the message stored at that location. Example: With a VOICE prefix number of 700, play message stored at table position seven.

Key-up and enter: 7 0 0 0 7
 └─┬─┘ └─┬─┘ Message Number
 └──────────┘ Voice Prefix Number

DVR Track Selection

To play one of the sixteen DVR tracks, key-up and enter the DVR prefix number followed by the track number. The CAT-300 will key the transmitter and play the message pre-recorded at that track. Example: With a DVR prefix number of 725, play track seven.

Key-up and enter: 7 2 5 0 7
 └─┬─┘ └─┬─┘ Track Number
 └──────────┘ DVR Control Number

DVR Signal Report

Key-up and enter the DVR prefix followed by a [*]. Un-key, the voice will say: "START TEST NOW". Key-up and record a seven second message. Un-key and the message will play back. You instantly know how your signal sounds through the repeater. This feature does not work with the Ming digital voice recorder.

Macro Execute [DX]

A macro is a series of commands, defined by the repeater owner. Macros permit the repeater owner to customize certain aspects of repeater operation to suit his or her particular needs. Once the CAT-300 decodes the assigned macro number the controller will execute the commands in the order they are stored within the macro.

Memory Files [DX]

Space is provided for four memory files. Each memory file includes: control channel settings, codes, timer values, CW ID buffer and voice messages one through twelve. When the CAT-300 is initialized, all files are filled with the default values. The memory recall prefix number will permit the user to copy into active memory a file from storage. To store active memory as a memory file, unlock the CAT-300 and use the [*19X] programming commands.

Active Memory Identification [DX]

Key-up and enter the memory recall prefix number followed by a 0. Un-key and the voice synthesizer will read back the memory file number. Example: With memory recall prefix number of 175, and current memory compares to file 2. The voice will say: "FILE ID IS TWO."

Key-up and enter: 1 7 5 0
 └─┬─┘ └──┬──┘
 └──┬──┘ Memory File Read Back
 └──┬──┘ Memory Recall Prefix Number.

Memory Recall [DX]

To copy a memory file into active memory, key-up and enter the memory recall prefix number followed by the file number to be loaded into active memory. Example: With a memory recall prefix of 175, move file 3 to active memory.

Key-up and enter: 1 7 5 3
 └─┬─┘ └──┬──┘
 └──┬──┘ File Number
 └──┬──┘ Memory Recall Prefix Number

User Function Control By Repeater Input

This feature permits repeater users to control the three user function switches with a simple DTMF entry. To control one of the switches, key-up and enter the user function control number followed by the switch number to be controlled and a [0] to turn the switch OFF, a [1] to turn the switch ON or a [2] to momentary change the switch for 0.5 seconds. Example: With a user function control number of 550, turn ON switch two.

Key-up and enter: 5 5 0 2 1
 └─┬─┘ └─┬─┘ └──┬──┘
 └──┬──┘ Command 0=Off 1=On 2=Change For 0.5 Seconds
 └──┬──┘ User Function Switch Number 1 through 3
 └──┬──┘ User Function Control Number

Serial Board Switch Control By Repeater Input

This feature permits repeater users to control the eight user function switches located on MF-1000 Serial Interface Card, with a simple DTMF entry. Key-up and enter the Serial board prefix number followed by one of the sixteen table location numbers. The CAT-300 will change the settings of the eight switches to conform to the pattern stored by the [*44XX] programming command. Example: With a prefix number of 575, set the switches to the conditions previously stored in memory at table position fifteen.

Key-up and enter: 5 7 5 1 5
 └─┬─┘ └─┬─┘ └──┬──┘
 └──┬──┘ Serial Board Switch Table Location Number
 └──┬──┘ Serial Board Switch Prefix Number

Control By Telephone

To control the CAT-300, call the repeater by telephone. When the CAT-300 answers the phone a beep will be heard. Enter the control operator prefix code followed by a (#) pound. The voice will say: "CONTROL READY." You need only enter the Zone number, Channel number and a (1) to turn the channel ON or a (0) to turn the channel OFF followed by the (#) pound. It is not necessary to enter the control operator prefix number before each command when controlling by phone. To terminate control by phone send [*0#].

Programming By Telephone

To program the CAT-300, call the repeater by telephone. When the CAT-300 answers the phone a beep will be heard. Enter the seven digit unlock number followed by a (#) pound. The voice will say: "CAT300 CONTROL." Programming by phone is identical to programming by radio except you must end each entry with a (#) pound. To terminate programming by phone send [*0#].

Repeater ID #1 (At Rest)

If the repeater has been at rest for a period in excess of the ID timer setting, typically ten minutes, when the repeater is keyed, the CAT-300 will send ID #1. This ID should be longer than ID #2 and include additional information about the repeater or sponsoring organization. Example: "WITH ONE HUNDRED WATTS OF RF POWER THIS IS THE W4XYZ REPEATER SYSTEM GOOD AFTERNOON."

Repeater ID #2 (Active)

If the repeater is in operation with a QSO in progress and it is time to identify the CAT-300 will send ID #2. This ID should be short so as not to interfere with the QSO in progress. Example: "W4XYZ REPEATER." This ID is also called as the final ID of the ten-minute period.

Unique Courtesy Tones

The CAT-300 determines which courtesy tone to send by reading voice message buffer 05. Since the courtesy tones are assigned a three-digit number and called from a voice message, any three digit voice word in the vocabulary list from Chapter 9 can be used as the courtesy tone. This includes: chimes, sound effects and even words like "OVER". The choice is yours.

Chapter 5 - Repeater Programming By DTMF Tone

This chapter describes how the CAT-300 controller is programmed by the repeater owner using a DTMF keypad. The various types of program commands are described in detail and examples are given in the following text.

Initialization

To initialize the CAT-300, set dipswitch #7 to ON and cycle DC power. During power-up, the voice will say: "RESET DATA LOAD COMPLETED." Set dip-switch #7 to OFF. Initialization consists of following operations:

Dip-switch #7 Initialization

1. All memory locations are cleared.
2. The control channels marked with an [*] are enabled.
3. The unlock number is loaded with the default value [1234567].
5. The control operator prefix code is loaded with the default value [100].
6. The control numbers are set to default values.
7. The timers are set to default values.
8. The voice message buffers are loaded with default messages.
9. ID #1 is loaded with "CAT THREE HUNDRED REPEATER."
10. ID #2 is loaded with "CAT THREE HUNDRED."
11. All active memory saves are filled with default values.
12. Load Hardware Input buffers with User Function Switch commands.

Programming the Unlock Control Number

To program the UNLOCK code, set dipswitch #8 to the ON position. The voice will say: "ENTER CONTROL." Key-up and enter a seven-digit number. Un-key, if the number is accepted, the voice will say: "DATA INPUTS OK." If the number is rejected, the voice will say: "ENTER CONTROL." Key-up and enter the seven-digit number. Set dipswitch #8 to the OFF position. NOTE: When the CAT-300 is powered up with dipswitch #7 set to ON, the unlock number defaults to: [1-2-3-4-5-6-7]

Unlocking the Controller By Radio

To unlock the controller, key-up and enter the seven digit unlock number. The voice will say: "CAT-300 CONTROL."

Locking the Controller By Radio

Key-up and send [*0]. Un-key, the controller will lock-up and the voice will say: "MANUAL EXIT." The CAT-300 will lock-up automatically when the programming timer expires. The voice will say: "TIMER EXIT." The programming time limit can be set with the [*615*] programming command.

Programming Controller By Telephone

To program the CAT-300, call the repeater by telephone. When the CAT-300 answers, a beep will be heard. Enter the seven digit unlock number followed by a (#) pound. The voice will say: "CAT-300 CONTROL." Programming by phone is identical to programming by radio except you must end each entry with a [#] pound. To terminate programming by phone send [*0#].

NOTE: The CAT-300 must be unlocked to perform the following procedures:

Internal Command Structure

The Internal Command Structure is a series of commands used to program the scheduler, two hardware input switch buffers and the macro strings. Each command is limited to four digits. Even number pointer commands will interrupt a QSO, while odd number pointers commands will not execute if COR is active. The following CAT-300 operations are controlled by the Internal Command Structure:

	Pointer	Zone	Channel	Action
Control Repeater	1	1-8	1-8	0-1-2
Action	0 = OFF	1 = ON	2 = Momentary	(0.2 second)
Operation	Pointer	Table Position		
Send Time of Day [DX]	20 21	00		
Send Day of Week [DX]	22 23	00		
Send Day and Month [DX]	24 25	00		
Send Salutation [DX]	26 27	00		
Send Voice Message	30 31	01-12		
Play DVR Track	32 33	01-16		
Send CW Buffer	34 35	00		
Send CW Character	36 37	00-46		
Execute Macro [DX]	50 51	01-10		
Load Memory File [DX]	52 53	01-04		
Time Delay Control (Seconds)	60	01-99		
PTT Control	62	00-01		
Expanded UF Switch Control	80 81	01-16		
Send Voice Vocabulary	9	000-999		

Figure 5-1

Scheduler Command Memory [DX]

This memory area is reserved for storage of scheduler activity. This includes the time the command is to be executed, and the action to be taken.

Read Scheduler Locations (01-40) [DX]

Key-up and send [*10XX]. Un-key and the voice will read back the status of the memory location. If there is no command stored at that memory location, the voice will say: "POSITION XX IS CLEAR." If a command is stored at that memory location, the voice will read back the time, day, and command stored.

Program Scheduler Locations (01-40) [DX]

Key-up and send [*11XX] followed by the hours, minutes, day of week, or day of month and month of year, and the command to be executed. Un-key and the voice will say: "CONTROL OK." Example: Set Zone 1 Channel 5 (ON) - 9:00 AM Every Friday (Store at Table Location 27)

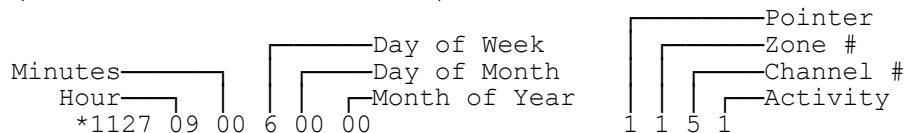

Example: Play DVR Track 7 - 6:00 PM Every Day (Store at Table Location 6)

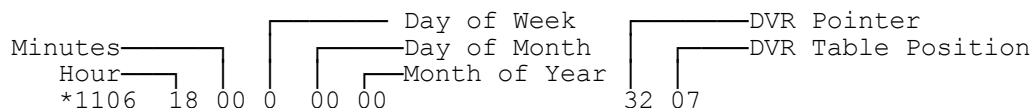

Example: Announce Time of Day - 7:30 AM - ON December 25th (Store at Table Location 07)

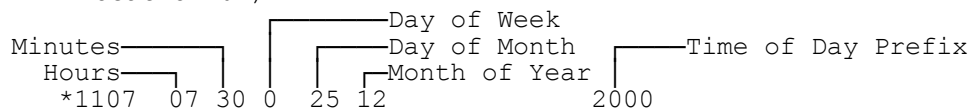

Example: Play DVR Track 9 - 30 minutes after every hour. Store at Table Location 26)

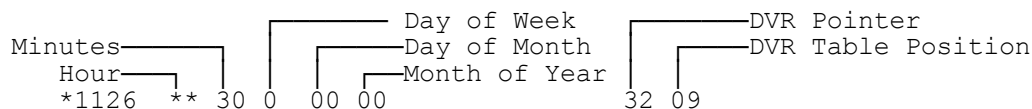

DAY OF WEEK SCHEDULER PROGRAMMING TABLE				
0=Daily	2=Monday	4=Wednesday	6=Friday	8=Weekdays
1=Sunday	3=Tuesday	5=Thursday	7=Saturday	9=Weekends

Figure 5-2

Erase Scheduler Locations (01-40) [DX]

Key-up and send [*12XX]. Un-key and the voice will say: "POSITION XX IS CLEAR."

Read Macro Locations (01-10) [DX]

Key-up and send [*13XX]. Un-key and voice will read back the macro control code number followed by the macro data commands stored at that memory location. If the location is empty, the voice will say: "NO MACRO."

Program Macro Locations (01-10) [DX]

Key-up and send [*14XX] followed by the macro control number and the string of internal commands (See Figure 5-1) to be executed by this macro. Un-key and the voice will say: "CONTROL OK." Example: Program the macro with a macro control number of 123 to announce the time and turn on Zone 2, Channel 4. (Store as memory location 3).

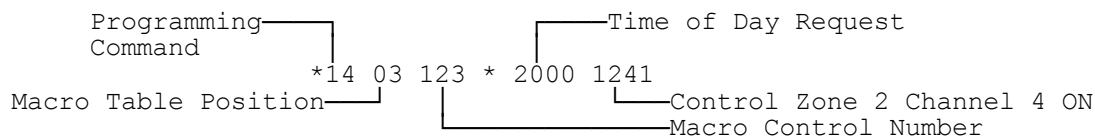

The Macro Control number [123] is the number entered by a repeater user to execute the macro.

Erase Macro Locations (01-10) [DX]

Key-up and send [*15XX]. Un-key and the voice will say: "CONTROL OK."

Read Hardware Input Switch Locations (1-2)

Key-up and send [*16X]. Un-key and voice will read back the Internal command stored at that switch memory location. If the location is empty, the voice will say: "POSITION IS CLEAR."

Program Hardware Input Switch Locations (1-2)

Key-up and send [*17X] followed by the internal command to be stored. See Figure 5-1. Un-key and the voice will say: "CONTROL OK." Example: Announce the time of day when switch 2 is activated.

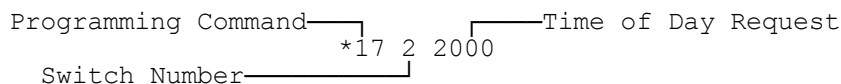

Erase Hardware Input Switch Locations (1-2)

Key-up and send [*18X]. Un-key and the voice synthesizer will say: "CONTROL OK."

Save Active Memory (1-4) [DX]

Save the current settings of active memory to be recalled later. Memory space is provided for four files. Configure the active memory to suite your special requirements. Use the [*19X] programming command to save the current settings of the control channels, codes, timers, twelve voice messages and CW buffer. Example: Save active memory as File #2. Key-up and send [*192]. Un-key and the voice will say: "PROGRAM FILE TWO OK."

Load Active Memory With Default Values [DX]

Key-up and send [*199]. Un-key and active memory will be loaded with the default values. The voice will say: "CONTROL OK." This programming command only changes the control channel settings, codes, timers, CW ID buffer and the twelve voice message buffers.

Send the Time of Day [DX]

Key-up and send [*20]. Un-key, the voice will read the time, day of week, month and day of month. Example: "THE TIME IS TWELVE FIFTEEN PM MONDAY JUNE FIVE."

Setting the Clock [DX]

Key-up and send [*21] followed by the hours, minutes, day of week, day of month, and month of year. See Figure 5-3 for the number that represents the day of week. Un-key and the voice will say "CONTROL OK." Example: 2:55 PM Monday January 25th. All entries must be double digit, except the day of week.

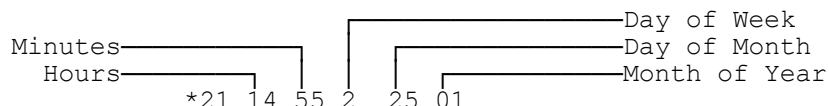

Hour	0-23	Sun=1	
Minute	0-59	Mon=2	Fri=6
Day of Week	1-7	Tue=3	Sat=7
Day of Month	1-31	Wed=4	
Month of Year	1-12	Thr=5	

Figure 5-3

Select 24 Hour Clock Operation

To select 24 hour clock announcements, key-up and enter [*222], un-key and the voice will say "CONTROL OK." To return to 12-hour clock announcements, key-up and enter [*221]. To read the current selection, key-up and enter [*220].

Voice Synthesizer Memory Storage

Space is provided for twelve user programmable messages of up to 23 words each.

Send Synthesized Voice Message Locations (01-12)

Key-up and send [*30XX]. Un-key and the voice synthesizer will say the message stored at memory location "XX".

Program Synthesized Voice Message Locations (01-12)

Key-up and send [*31XX], followed by the three digit numbers that represents the words required to construct the message. Memory space is provided for twenty-three entries. Refer to Chapter 9, Voice Vocabulary Word List. Example: Load Repeater ID #1 with "W4XYZ Repeater"

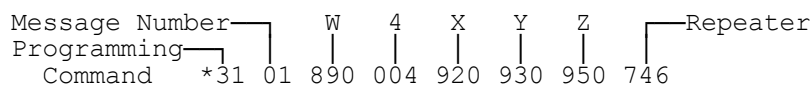

VOICE MESSAGE NUMBER TABLE			
01	Repeater ID #1	02	Repeater ID #2
03	Squelch Tail #1	04	Transmitter Drop
05	Courtesy Tone	06	Repeater Timeout
07	Repeater Timeout Clear	08	A/P Disconnect
09	Time of Day (Message #1)	10	Grandfather Clock (Message #2)
11	Message #3	12	Message #4

Figure 5-4

Program Voice Message With Time Variables [DX]

To insert the time-of-day into a voice messages load the number [100]. Example: Load ID #1 with "THE TIME IS [ACTUAL TIME] AND THIS IS THE W4XYZ REPEATER." Other time variables include: [101 - Day of the Week], [102 - Day and Month] and [103 - Salutation].

Message Number — [Actual Time]
 *31 01 830 838 482 100 231 833 482 830 890 004 920 930 950 746

User Function Control by Voice Message.

The voice message buffers can also control the three User Function switches. If during the execution of a voice message, a User Function switch command (111 through 119) is encountered, the CAT-300 will set the switch and then continue with the remainder of the voice message.

USER FUNCTION VOICE CONTROL COMMANDS		
111 UF #1 OFF	114 UF #2 OFF	117 UF #3 OFF
112 UF #1 ON	115 UF #2 ON	118 UF #3 ON
113 UF #1 MOMENTARY	116 UF #2 MOMENTARY	119 UF #3 MOMENTARY

Figure 5-5

DVR Track Selection by Voice Message

The voice message buffers can be used to select one of the sixteen DVR voice tracks. If during the execution of a voice message, a DVR track command (140 through 155) is encountered, the CAT-300 will play the recorded message stored at that track.

DIGITAL VOICE RECORDER TRACK CONTROL COMMANDS			
140 TRACK #1	144 TRACK #5	148 TRACK #9	152 TRACK #13
141 TRACK #2	145 TRACK #6	149 TRACK #10	153 TRACK #14
142 TRACK #3	146 TRACK #7	150 TRACK #11	154 TRACK #15
143 TRACK #4	147 TRACK #8	151 TRACK #12	155 TRACK #16

Figure 5-6

Courtesy Tone Selection by Voice Message

The voice message buffers can be used to generate courtesy tones. If during the execution of a voice message, a courtesy tone command (161 through 168) is encountered, the CAT-300 will generate the courtesy tone stored at that memory location. See Figure 5-7.

COURTESY TONE CONTROL COMMANDS			
161 TONE #1	163 TONE #3	165 TONE #5	167 TONE #7
162 TONE #2	164 TONE #4	166 TONE #6	168 TONE #8

Figure 5-7

Load Courtesy Tone Repeater Receiver

Key-up and send [*3105], followed by the three-digit number that represents the desired courtesy tone from the courtesy tone command table at Figure 5-7. Un-key and the voice will say: "CONTROL OK." Example: Select courtesy tone #3.

Programming Command — *31 05 163 — Courtesy Tone #3
 Command — *31 05 163 — Message Number

Program Synthesized Voice Message With CW ID

To send the CW ID in place of a voice messages, load the number [170] in the voice message buffer. Please note: the CAT-300 will not pass receive audio when the CW buffer is activated by the [170] programming command. Example: Send the CW ID as ID #2.

Programming Command — *31 02 170 — CW ID command
 Command — *31 02 170 — Message Number

Erase Synthesized Voice Message Locations (01-40)

Key-up and send [*32XX]. Un-key and the voice will say: "CONTROL OK." The voice message will be erased at location [XX].

CW ID Memory Storage

Memory space is provided for one CW identification. The buffer will accept 31 characters. If a repeater user talks over a voice ID, the CAT-300 will switch to the CW ID. If both voice ID messages are disabled, (Zone 3 Channel 1 and Zone 3 Channel 2 turned OFF), the controller will ID in CW only. During initialization, the buffer is loaded with "CAT-300 REPEATER."

Send Repeater CW ID

Key-up and send [*331]. Un-key and the CAT-300 will send the CW ID. The CW ID will be sent by the transmitter even if it was requested by telephone.

Control - Prefix Number Memory

This memory area is reserved for storage of control and prefix numbers. These numbers can be from one to seven digits and will change to a default value when the CAT-300 is powered up with dip-switch #7 set to the ON position.

Control Operator Prefix Number [*501*]

This number must precede the command used to change the settings of the repeater's control channels in Zones 1 through 8. Example: To program a Control Operator Prefix Number of 100, key-up and send [*501*100], Un-key and the voice will say: "CONTROL OK." Access to this number should be limited to control operators.

Time Request Number [*502*] [DX]

This number must be entered to request the time of day announcement. Example: To program a Time Request Number of 400, key-up and send [*502*400]. Un-key and the voice will say: "CONTROL OK."

Memory Recall Prefix [*503*]

This number must precede the command used to execute a memory move from storage into active memory. Example: To program a Memory Recall Prefix Number of 175, key-up and send [*503*175], Un-key and the voice will say: "CONTROL OK."

DTMF Access Number [*504*]

When the repeater is in the DTMF Access Mode it will not respond to a COR input. The repeater user must enter a DTMF access number to activate the repeater. When the repeater returns to rest for a period determined by the sleep timer, the number must be re-entered to activate the repeater. Example: To program a DTMF Access Number of 325, key-up and send [*504*325]. Un-key and the voice will say: "CONTROL OK."

DTMF Pad Test Number [*505*]

This number must be entered to initiate a DTMF keypad test. Example: To program a DTMF Pad Test Number of 375, key-up and send [*505*375]. Un-key and the voice will say: "CONTROL OK."

User Function Switch Number [*506*]

This number must precede the command to change the settings of the user function switches on the CAT-300. Example: To program a User Function Switch Number of 550, key-up and send [*506*550]. Un-key and the voice will say: "CONTROL OK."

Autopatch Access Number [*507*]

This number must be entered to access the autopatch. Example: To program an autopatch access number of *, key-up and send [*507*#]. Un-key and the voice will say: "CONTROL OK."

Autopatch Disconnect Number [*508*]

This number must be entered to terminate the autopatch. Example: To program an autopatch termination number of #, key-up and send [*508*#]. Un-key and the voice will say: "CONTROL OK."

User Speed Dial Prefix Number [*509*]

This number must be entered to access a user speed dial location. Example: To program the speed dial prefix 6, key-up and send [*509*6]. Un-key and the voice will say: "CONTROL OK." This number must precede the speed dial table location. With the prefix 6, the speed dial numbers will be 600 through 624 or 699.

Emergency Speed Dial Prefix Number [*510*]

This number must be entered to access an emergency speed dial location. Example: To program the speed dial prefix 9, key-up and send [*510*9]. Un-key and the voice will say: "CONTROL OK." This number must precede the speed dial location number. With the prefix 9, the speed dial numbers will be 90 through 94.

Voice Demonstration Control Number [*511*]

This number must be entered to PLAY one of the voice messages. This number must precede the voice message number. Example: To program a Voice Demonstration Control Number of 700, key-up and send [*511*700]. Un-key and the voice will say: "CONTROL OK."

Reverse Autopatch Access Number [*512*]

This number must be entered to access the reverse autopatch. Example: To program the reverse autopatch access number 800, key-up and send [*512*800]. Un-key and the voice will say: "CONTROL OK." This number must precede the speed dial table position numbers.

DVR Control Number [*513*]

This number must be entered to PLAY one of the DVR tracks. This number must precede the track number. Example: To program a DVR Control Number of 725, key-up and send [*513*725]. Un-key and the voice will say: "CONTROL OK."

Expanded User Function Switch Number [*514*]

This number must precede the command to change the settings of the expanded user function switches on the MF-1000 Serial Interface Card. Example: To program a user function switch control number of 575, key-up and send [*514*575]. Un-key and the voice will say: "CONTROL OK."

Read Control Number [*501 - *514]

Key-up and send [*501]. Un-key and the voice synthesizer will read back the Control Operator Prefix numbers. The voice will say: "PRESET CODE FIVE ZERO ONE IS ONE ZERO ZERO."

Timer Memory

This memory area is reserved for storage of sixteen timers. These timers are user programmable. If the CAT-300 is initialize by applying power with dip-switch #7 in the ON position, the timers will be automatically loaded with default times.

Repeater Time-out [*601*]

The maximum length of a transmission is limited by the repeater time-out timer. This timer is programmable between 1.0 and 1799 seconds. Example: To program this timer to 2 minutes, key-up and enter [*601*120]. Un-key and the voice will say: "CONTROL OK." When initialize, this timer will default to 180 seconds.

Repeater Sleep Timer [*602*]

This timer determines the time required for the repeater to be at rest before the DTMF access code is required to activate the repeater. This timer is programmable between 1.0 and 1799 seconds. When initialize, this timer will default to 60 seconds.

Repeater Turn on Delay Timer [*603*]

When the repeater is at rest, this timer determines the time COR must be present before the repeater will activate. This timer is programmable between 0.1 and 9.9 seconds. Example: To program this timer to 1.5 seconds, key-up and enter [*603*15]. Un-key and the voice will say: "CONTROL OK." When initialize, this timer will default to 1.0 seconds.

COR Drop to Courtesy Beep Timer [*604*]

This timer determines the time between loss of COR and the generation of the courtesy beep. This timer is programmable between 0.1 and 9.9 seconds. When initialize, this timer will default to 1 second.

Courtesy Beep to PTT Drop Timer [*605*]

This timer determines the time between the generation of the courtesy beep and the time the repeater transmitter turns off. This timer is programmable between 0.1 and 9.9 seconds. When initialize, this timer will default to 4 seconds.

DTMF Mute Delay Timer [*606*]

This timer determines the time the transmit audio will continue to be muted after the entry of the last DTMF tone. This timer is programmable between 0.1 and 9.9 seconds. When initialize, this timer will default to 1 second.

Repeater ID Timer [*607*]

This timer sets the time between transmissions of the repeater ID. The ID occurs when a repeater user stops transmitting. This timer is programmable between 1.0 and 1799 seconds. When initialize, the timer defaults to 480 seconds.

Squelch Tail Message Timer [*608*]

This timer sets the time between transmissions of the squelch tail message. The message occurs when a repeater user stops transmitting. This timer is programmable between 1.0 and 1799 seconds. When initialize, the timer defaults to 1799 seconds.

Drop Out Message Timer [*609*]

This timer sets the time between transmissions of the drop out message. The message occurs when a repeater stops transmitting. This timer is programmable between 1.0 and 1799 seconds. When initialize, the timer defaults to 1799 seconds.

Voice Delay Timer [*610*]

The CAT-300 generates a PTT output and after a short delay the voice speaks. This delay is field programmable. This feature is useful in repeater systems using CTCSS tone squelch or multiple linking where the system is slow to come up. The voice delay timer can be programmed between 0.1 and 9.9 seconds. When initialize, the timer defaults to 1.0 seconds.

Autopatch Timer [*611*]

This timer sets the maximum length of an autopatch. This timer is programmable between 1.0 and 1799 seconds. When initialize, this timer will default to 180 seconds.

Autopatch Activity Timer [*612*]

The repeater user must periodically key-up to maintain the autopatch. Five seconds before the autopatch activity timer is to expire, the controller will generate a warning beep. The user must key-up or the autopatch will disconnect.

This timer is programmable between 1.0 and 1799 seconds. When initialize, this timer will default to 30 seconds.

DTMF Pre-window Timer [*613*]

This timer determines the time between the presence of COR and the point where the DTMF window opens to accept DTMF entries. This timer is programmable between 0.1 and 9.9 seconds. When initialized, this timer will default to 2 seconds.

DTMF Window Timer [*614*]

This timer sets the length of time the window will remain open to accept DTMF entry. This timer is programmable between 0.1 and 9.9 seconds. When initialized, this timer will default to 8 second.

Repeater Programming Timer [*615*]

During the programming mode, this timer determines the maximum time the controller remains unlocked. This timer is programmable between 1 and 1799 seconds. When initialize, this timer will default to 300 second.

Ring Detector Timer [*616*]

This timer sets the delay between detection of the first ring and when the CAT-300 answers a control operator call in. This timer is programmable between 1.0 and 1799 seconds. When initialize, the timer defaults to 2.0 seconds.

Read Timer Setting [*601 - *616]

Key-up and send [*601]. Un-key and the voice synthesizer will read back the setting of the repeater's time-out timer. The voice will say: "TIMER 601 IS THREE MINUTES."

User Speed Dial Memory

This memory area is reserved for storage of 25 or 100 phone numbers with call letter identification. Space is provided for an eleven-digit phone number with an ID of eight numbers, letters or words from the Voice Vocabulary Word List.

Read User Speed Dial Locations (00-24) (00-99) [DX]

Key-up and send [*70XX]. Un-key and the voice synthesizer will read back the status of the memory location. If there is no number stored at that memory location, the voice will say: "POSITION XX IS CLEAR." If a User Speed Dial is stored at that memory location, the voice will read the phone number and ID.

Program User Speed Dial Locations (00-24) (00-99) [DX]

Key-up and send [*71XX] followed by up to a eleven digit phone number, a [*] separator and up to eight words from the voice synthesizer vocabulary list. Un-key and the voice will say: "CONTROL OK." Example: 978-6171 W4XYZ (Store at table position 15).

	Phone Number	W	4	X	Y	Z
Table Position	_____					
	*71 15 9786171 *	890	004	920	930	950

	Phone Number	W	4	X	Y	Z
Table Position	_____					
Pre-Dial Number	*71 05 9 ** 9786171 *	890	004	920	930	950
	_____	One Second Dialing Delay				

Erase User Speed Dial Locations (00-24) (00-99) [DX]

Key-up and send [*72XX]. Un-key and the voice will say: "POSITION XX IS CLEAR"

Prefix Number Memory

This memory area is reserved for the storage of 100 telephone prefix numbers. Space is provided for a look-up table of twenty positions. Each position will hold five prefix numbers.

Read Prefix Number Locations (00-19) [DX]

Key-up and send [*73XX]. Un-key and the voice synthesizer will read back the prefix numbers stored at that memory location. If there are no numbers stored at that memory location, the voice will say: "NO TELEPHONE PREFIX NUMBERS"

Program Prefix Number Locations (00-19) [DX]

Key-up and send [*74XX] followed by up to five prefix numbers to be added to the look-up table. Un-key and the voice will say: "CONTROL OK." Example: Add prefix numbers 978, 525, 477, and 395 (Store at table position 3).

Table Position	_____	_____	_____	_____	_____	Prefix Numbers
	*74 03	978	525	477	395	

Erase Prefix Number Locations (00-19) [DX]

Key-up and send [*75XX]. Un-key and the voice will say: "CONTROL OK"

Area Code Memory

This memory area is reserved for the storage of 10 area code numbers. Space is provided for a look-up table of two positions. Each position will hold five area code numbers.

Read Area Code Locations (00-09) [DX]

Key-up and send [*76XX]. Un-key and the voice synthesizer will read back the area code numbers stored at that memory location. If there are no numbers stored at that memory location, the voice will say: "NO AREA CODE NUMBERS"

Program Area Code Locations (00-09) [DX]

Key-up and send [*77XX] followed by up to five area code numbers to be added to the look-up table. Un-key and the voice will say: "CONTROL OK." Example: Add area code numbers 305 and 407 (Store at table position 00).

Table Position Area Code Numbers
 *77 00 305 407

Erase Area Code Locations (00-09) [DX]

Key-up and send [*78XX]. Un-key and the voice will say: "CONTROL OK"

Emergency Speed Dial Memory

This memory area is reserved for five phone numbers with identification. Space is provided for up to a eleven digit phone number with an identification of eight numbers, letters or word from the voice synthesizer word list.

Read Emergency Speed Dial Locations (0-4)

Key-up and send [*80X]. Un-key and the voice will read back the status of the memory location. If there is no number stored at that memory location, the voice will say: "POSITION X IS CLEAR." If an Emergency Speed Dial is stored at that memory location, the voice will read the phone number and identification.

Program Emergency Speed Dial Locations (0-4)

Key-up and send [*81X] followed by the phone number, a [*] separator and up to eight words from the voice vocabulary list. Un-key and the voice will say: "CONTROL OK." Example: 525-2500 FIRE DEPARTMENT (Store at table position 3)

Phone Number
 *813 5252500 * 381 321
 FIRE DEPARTMENT

Erase Emergency Speed Dial Locations (0-4)

Key-up and send [*82X]. Un-key and the voice will say: "POSITION X IS CLEAR"

Pre-Dial Number

When the CAT-300 is initialized, the pre-dial number is loaded with "9". If Zone 4 Channel 8 is enabled, this number will precede all manually dialed numbers. If Zone 8 Channel 4 is enabled, this number will precede all speed dial numbers. Memory space is provided for a pre-dial number of up to seven digits.

Read Pre-Dial Number

To read the pre-dial number, key-up and enter [*89]. Un-key and the voice synthesizer will read back the number.

Program Pre-Dial Number

To program the pre-dial number key-up and enter [*89] followed by the number. Space is provided for a number of up to seven digits. Example: to program the number "7", key-up and enter [*897]. Un-key and the voice will say: "CONTROL OK". To program caller ID suppression, key-up and enter [*89*67].

Audio Test Tone

The CAT-300 will generate a 1000Hz test tone to modulate the transmitter at TP2 and a DTMF [A] to the phone line at TP1. The phone line will not go off hook. These tones are use as a reference when setting audio levels. To activate the tones, key-up and enter [*90]. The length of the tones are 30 seconds.

Courtesy Tone

Memory space is provided for the storage of eight custom courtesy tones. Each tone can consist of up to three different tone frequencies of various lengths and separations.

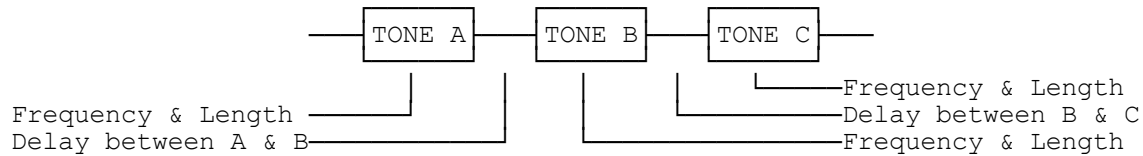

Figure 5-10

Send Courtesy Tone Location (1-8)

To send a courtesy tone, key-up and send [*91X]. Un-key and the CAT-300 will transmit the courtesy tone. "X" represents the courtesy tone table location.

Program Courtesy Tone Location (1-8)

To program a courtesy tone, key-up and send [*92X], followed by the frequency, duration and separation from table at Figure 5-11. Example: Program courtesy tone table location 5 with a tone of 1000Hz and a duration of 150 milliseconds.

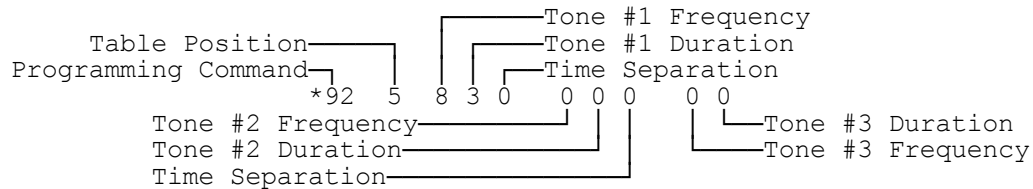

To program a multiple courtesy tone, key-up and send [*92X], followed by the desired tone frequencies, durations and separations. Example: Program courtesy tone table location 1 with a three-frequency tone.

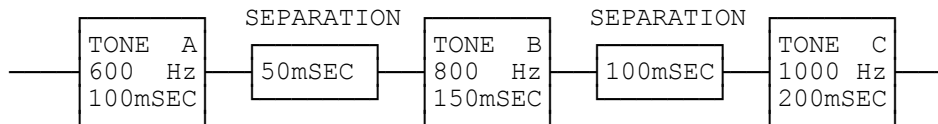

The [*92X] programming command is used to develop eight custom courtesy tones 161 through 168.

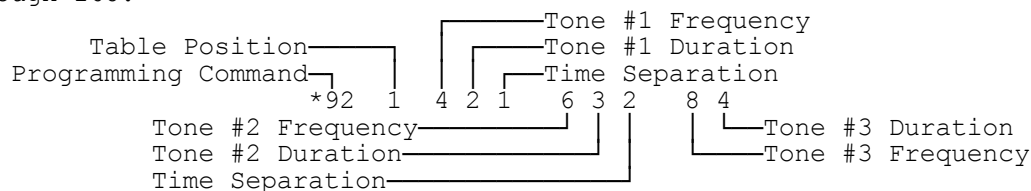

TONE FREQUENCY TABLE (Hertz)									
0=OFF	1=300	2=400	3=500	4=600	5=700	6=800	7=900	8=1000	
TONE DURATION - TONE SEPARATION TABLE (Milliseconds)									
0=0	1=50	2=100	3=150	4=200	5=250	6=300	7=350	8=400	9=450

Figure 5-11

Erase Courtesy Tone Location (1-8)

Key-up and send [*93X]. Un-key and the voice will say: "CONTROL OK."

Select Courtesy Tone

To select tone "163" as the repeater's courtesy beep, load Voice Message buffer #05 with "163." Example: Enter *3105 163.

Westminster Chimes on Grandfather Clock [DX]

The courtesy tone generator can be used to generate Westminster chimes during the Grandfather clock message announcement. Enter the following programming commands:

[*926 894 694 79]
[*927 499 494 79]
[*928 894 690]
[*3110 166 963 167 963 168 963 100]

Figure 5-12

Digital Voice Recorder

The CAT-300 will support the DVR-1000 Digital Voice Recorder for true voice message announcements. Substitute DVR tracks for voice messages, speed dial identifications and courtesy tones. For additional information on how to record tracks over the telephone line, consult Chapter 16 of this manual

The CAT-300 also supports the Ming DVM-58, however the MF-1000 Serial Interface Card and a special cable are required. See Chapter 7 of this manual. The erase command and recording by telephone do not work with the Ming DVM-58.

Play Digital Voice Recorder Tracks (01-16)

Key-up and send [*94XX]. Un-key and the CAT-300 will play the prerecorded message stored at track "XX"

Record Digital Voice Recorder Tracks (01-16)

Key-up and send [*95XX]. Un-key and the voice will say: "START MESSAGE". Key-up and enter the message to be stored at track "XX".

Erase Digital Voice Recorder Tracks (01-16)

Key-up and send [*96XX]. Un-key and the voice will say: "CONTROL OK".

Exit Programming Mode [*0]

To exit the programming mode and return to normal repeater operation, key-up and send [*0]. Un-key and the voice will say: "MANUAL EXIT." If you fail to exit the programming mode, when the programming timer [*615*] expires, the CAT-300 will automatically return to normal repeater operation. The voice will say: "TIMER EXIT."

DTMF Programming Table

ENTRY	DESCRIPTION
*10XX	READ SCHEDULER COMMAND [DX]
*11XX	PROGRAM SCHEDULER COMMAND [DX]
*12XX	ERASE SCHEDULER COMMAND [DX]
*13XX	READ MACRO [DX]
*14XX	PROGRAM MACRO [DX]
*15XX	ERASE MACRO [DX]
*16X	READ HARDWARE INPUT SWITCH
*17X	PROGRAM HARDWARE INPUT SWITCH
*18X	ERASE HARDWARE INPUT SWITCH
*19X	SAVE ACTIVE MEMORY [DX]
*199	INITIALIZE ACTIVE MEMORY [DX]

ENTRY	DESCRIPTION
*20	SEND TIME OF DAY [DX]
*21	PROGRAM TIME OF DAY [DX]
*220	READ CLOCK SELECTION
*221	SET CLOCK FOR 12 HOUR TIME
*222	SET CLOCK FOR 24 HOUR TIME
*280	READ DVR CONTROL SELECTION
*281	SELECT DVR-1000 DIGITAL VOICE RECORDER
*282	SELECT DVM-58 MING DIGITAL VOICE RECORDER

ENTRY	DESCRIPTION
*30XX	SEND VOICE SYNTHESIZER
*31XX	PROGRAM VOICE SYNTHESIZER
*32XX	ERASE VOICE SYNTHESIZER
*331	SEND CW ID
*341	PROGRAM CW ID
*351	ERASE CW ID

ENTRY	DESCRIPTION
*43XX	READ EXPANDED USER FUNCTION SWITCHES
*44XX	PROGRAM EXPANDED USER FUNCTION SWITCHES
*45XX	ERASE EXPANDED USER FUNCTION SWITCHES

ENTRY	DESCRIPTION	DEFAULT
501	CONTROL OPERATOR PREFIX CODE	100
502	TIME OF DAY REQUEST CODE [DX]	400
503	MEMORY RECALL PREFIX CODE [DX]	175
504	DTMF ACCESS CODE	325
505	DTMF PAD TEST CODE	375
506	USER FUNCTION SWITCH PREFIX CODE	550
507	AUTOPATCH ACCESS CODE	*
508	AUTOPATCH DISCONNECT CODE	#
509	USER SPEED DIAL PREFIX CODE	6
510	EMERGENCY SPEED DIAL PREFIX CODE	9
511	VOICE MESSAGE DEMO PREFIX CODE	700
512	REVERSE AUTOPATCH CODE	800
513	DVR TRACK PREFIX CODE	725
514	EXPANDED USER FUNCTION SWITCH PREFIX CODE	575

ENTRY	TIMER DESCRIPTION	RANGE	DEFAULT
601	REPEATER TIME-OUT	1-1799	180
602	REPEATER SLEEP TIME	1-1799	60
603	TURN ON DELAY TIME	.1-9.9	1.0
604	COR DROP TO BEEP TIME	.1-9.9	1.0
605	BEEP TO PTT DROP TIME	.1-9.9	4.0
606	DTMF MUTE DELAY TIME	.1-9.9	1.0
607	REPEATER ID TIME	1-1799	480
608	SQUELCH MESSAGE TIME	1-1799	1799
609	DROP OUT MESSAGE TIME	1-1799	1799
610	VOICE DELAY TIMER	.1-9.9	1.0
611	AUTOPATCH LENGTH TIME	1-1799	180
612	AUTOPATCH ACTIVITY TIME	1-1799	30
613	DTMF PRE-WINDOW TIME	.1-9.9	2.0
614	DTMF WINDOW TIME	.1-9.9	8.0
615	PROGRAM MAX LENGTH TIME	1-1799	500
616	RING DETECTOR TIME	1-1799	2.0

ENTRY	DESCRIPTION
*70XX	READ USER SPEED DIAL
*71XX	PROGRAM USER SPEED DIAL
*72XX	ERASE USER SPEED DIAL
*73XX	READ PREFIX CODE [DX]
*74XX	PROGRAM PREFIX CODE [DX]
*75XX	ERASE PREFIX CODE [DX]
*76XX	READ AREA CODE [DX]
*77XX	PROGRAM AREA CODE [DX]
*78XX	ERASE AREA CODE [DX]

ENTRY	DESCRIPTION
*80X	READ EMERGENCY SPEED DIAL
*81X	PROGRAM EMERGENCY SPEED DIAL
*82X	ERASE EMERGENCY SPEED DIAL
*89	PROGRAM PRE-DIAL NUMBER

ENTRY	DESCRIPTION
*90	GENERATE 1000Hz AND [DTMF A] TEST TONES
*91X	SEND COURTESY TONE
*92X	PROGRAM COURTESY TONE
*93X	ERASE COURTESY TONE
*94XX	PLAY DIGITAL VOICE RECORDER TRACK
*95XX	RECORD DIGITAL VOICE RECORDER TRACK
*96XX	ERASE DIGITAL VOICE RECORDER TRACK

ENTRY	DESCRIPTION
*0	MANUAL EXIT

Chapter 6 - Interfacing to Other Equipment

Interfacing the CAT-300 to your repeater system is a simple matter. A minimum of two inputs and two outputs are required for the CAT-300 to control a repeater. They are:

1. A COR signal to indicate when a signal is being received.
2. A RX audio signal containing DTMF tones to be processed for control.
3. A PUSH-TO-TALK signal to tell the repeater transmitter to turn ON.
4. A TRANSMIT AUDIO signal containing a combination of receive audio, synthesized voice, and courtesy tone.

Additional connections are required to realize all features of the CAT-300.

Determining COR Logic

Locate your repeater receiver's COR output. This line has a DC voltage that changes state when a signal is being received. If the COR line is 0 volts and goes to a positive voltage when a signal is received it is said to be (positive logic) or active HIGH. If the COR line is a positive voltage, and goes to 0 volts when a signal is received it is said to be (negative logic) or active LOW.

Note: 0 volts is any voltage less than 0.8VDC. A positive voltage is any voltage greater than 3.0VDC. Set dipswitch #1 on the CAT-300 to ON for (negative logic) and OFF for (positive logic).

Connection to Receiver

Connect the repeater receiver audio output to J3-13 and the COR to J3-6 of the CAT-300. Measure the COR level when the receiver is active. Verify this line changes from less than 0.8VDC to greater than 3.0 VDC. If the COR line will not meet these limits it may be necessary to add an external pull-up resistor or transistor to the COR line.

Connection to Transmitter

Locate your repeater's Push-To-Talk input. When grounded, this line will make the repeater transmit. Connect the CAT-300 PTT output (J3-10) to this line. Locate your repeater's TX audio input. This is the line where the audio signal used to modulate the transmitter is applied. Connect the TX audio (J3-11) to this line.

Interface Review

1. Are dipswitches #1 through #8 in their proper positions?
2. Is the PTT output at J3-10 connected to the transmitter PTT input?
3. Is the TX Audio at J3-11 connected to the transmitter audio input?
4. Is the COR at J3-6 connected to the repeater receiver COR output?
5. Is dipswitch #1 ON for active low COR or OFF for active high COR?
6. Is the COR level changing from less than 0.8 to greater than 3.0 VDC?
7. Is the RX Audio at J3-13 connected to the receiver audio output?
8. Is the audio input level TP4 sufficient for the DTMF decoder?

Power Supply

The CAT-300 is powered by an external 12VDC power supply. Connect the positive lead of the supply to the center pin of the coaxial power connector J1 and the negative lead to the outer conductor.

Audio Level Adjustment (Receiver)

The audio mixing-switching circuits of the CAT-300 are optimized around an input and output of -10dBm (220mVAC RMS). For best results the receiver audio input should be 220mV when a DTMF tone is being received. While providing a DTMF audio input at J3-13, adjust the RX Audio level control (R17) for an audio level at TP4 of (220mVAC RMS).

Audio Level Adjustment (Transmitter)

Adjust the TX Audio level control (R5) for (220mVAC RMS) at TP2.

Audio Level Adjustment (Beep)

Unlock the CAT-300 and enter the [*90] programming command to produce the 1000Hz test tone. Adjust the BEEP Level control (R31) for a transmit audio output level of (90mVAC RMS) at TP2. Repeat the [*90] programming command to produce the test tone. Check the audio level at TP1. The voltage should be approximately (300mVAC RMS). Exit the programming mode.

Audio Level Adjustment (Transmitter Deviation)

Once the RX and BEEP levels are balanced, adjust the TX Audio control (R5) for the desired level of modulation while monitoring the repeater's transmitter. If your repeater's transmit audio input is very sensitive and you find the TX Audio level control is set to minimum, it is strongly recommended that an external voltage divider be installed at the input of the transmitter. This will permit you to increase the TX audio output from the controller and will insure an acceptable transmit audio signal to noise ratio.

Audio Level Adjustment (Voice Synthesizer)

Compare the receive and synthesized voice audio and adjust the VOICE Level (R35) as desired. For best quality speech, the synthesized voice should not exceed 3KHz deviation.

Audio Level Adjustment (CW ID And Courtesy Tone)

Compare the receive and CW ID audio and adjust the BEEP Level (R31) as desired. For best results the CW ID should not exceed 1.5KHz deviation. This will insure that repeater users will always be able to talk over the CW ID when it comes on during a QSO in progress.

Audio Level Adjustment (Autopatch)

Access the autopatch. With the CAT-300 in the autopatch mode, adjust the PHONE IN (R20) for the desired level of phone audio at the transmitter. During an autopatch the phone audio input should modulate the transmitter at the same level as audio from the repeater's receiver. Adjust the PHONE OUT (R18) for the desired level of receive audio into the telephone line.

Audio Level Adjustment (Control Operator Call-in)

Call the CAT-300 on the telephone and enter the control operator mode [100#]. Interrogate the control channels and adjust VOC PHONE OUT control (R19) for the desired voice synthesizer level.

Repeater Interface (J3)

Connector J3 provides an interface to the repeater.

Repeater Interface (J3)		
1. UF Switch In #1	2. UF Switch In #2	3. No Connection
4. CTCSS	5. No Connection	6. COR
7. UF Switch Out #1	8. UF Switch Out #2	9. UF Switch Out #3
10. PTT	11. TX Audio	12. No Connection
13. RX Audio	14. Ground	15. Ground
16. +12VDC	17. Ground	18. Ground
19. Ground	20. Ground	21. Ground
22. Ground	23. TX Audio	24. Ground
25. Ground		

Figure 6-1

Accessory Interface (J4)

Connector J4 provides the interface for the DVR-1000 Digital Voice Recorder, Serial Card and the CI-300 Computer Interface.

Accessory Interface (J4)			
1. +12 Volts	2. Ground	3. No Connection	4. Serial Strobe
5. Busy DVR	6. Serial Data	7. Serial Clock	8. TX Audio
9. PTT	10. Serial Strobe	11. COR	12. Audio From DVR
13. RX Audio	14. Audio To DVR		

Figure 6-2

Audio Delay Interface (J5)

This interface is used to connect the DL-1000 audio delay board. The CAT-300 is shipped from the factory with a jumper installed across pins 1 and 2. This completes the receive audio path. An audio delay board connected to J5 will eliminate the receiver squelch noise crash and the chirp of the first DTMF tone when muting is enabled. Refer to Chapter 15 of this manual.

Memory Select Jumper (J6)

This jumper changes address line selection. When a DS1220Y is installed for U12 jumper pins 2 and 3 to select (2K) RAM size. When a DS1243Y is installed for U12 jumper pins 1 and 2 to select (8K) RAM size.

Test Point TP1 - Telephone Audio Output

This test point displays the audio generated by the controller and sent to the phone line during an autopatch or control operator call in. It also displays audio received from the telephone line.

Test Point TP2 - Transmitter Audio

This test point displays the audio generated by the controller to modulate the repeater's transmitter. This includes receive audio, courtesy tone audio, CW ID audio and voice synthesizer audio. During an autopatch audio from the phone line is also present at TP2.

Test Point TP3 - Receiver Audio

This test point displays receive audio and phone line audio input during an autopatch or control operator call-in. This test point is not used to adjust the audio levels. However it is useful during troubleshooting the audio path.

Test Point TP4 - DTMF Decoder Audio

This test point displays the audio present at the input of the DTMF decoder (U6). For proper decoder operation the DTMF audio should be greater than (200mVAC RMS). When measuring this test point, make sure RF from the repeaters transmitter or your HT is not being picked-up on the voltmeter leads. This will cause an erroneous indication that will disrupt the alignment procedure. Set your HT to the low power position and hold it away from the controller and voltmeter leads or have someone off-site generate the DTMF tones.

Header Pin Assignments

Header connectors on the CAT-300, DVR-100, DL-1000, MF-1000 and RBS-1000 use the same numbering system. Looking at the board's solder side, one of the header pins is connected to a square solder pad. This pin is always pin one. One row of pins are assigned odd numbers while the other row of pins are assigned even numbers. See Figure 6-3.

Component Side View Of Headers

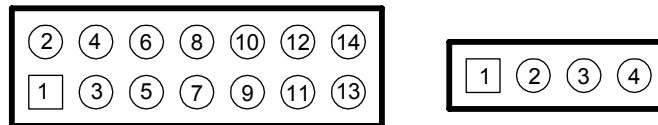

Figure 6-3

Connection to CTCSS Decoder

If your repeater receiver has a CTCSS decoder logic output, connect it to J3-4. For proper operation, the CTCSS decoder input must be connected to the discriminator audio output. Speaker or top of volume control audio exhibits low frequency roll-off. This will cause the CTCSS decoder output to toggle during voice peaks and the receive audio will cut out. Connect the TS-64 CTCSS Encoder/Decoder assembly to the CAT-300 as described in Figure 6-4.

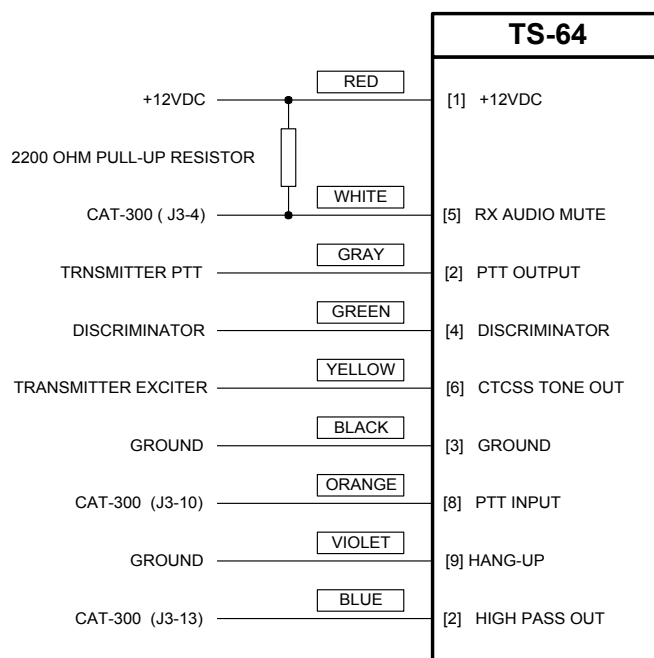

Figure 6-4

Positive Current Transmitter PTT

The CAT-300 keys the transmitter by grounding the PTT line. Some transmitters require a DC current usually from a 12 volt DC supply to key. In these cases a switching device must be installed between the transmitter and the CAT-300 Push-to-Talk output at J3-10. Figure 6-5 describes two possible circuits that will supply the transmitter. Use caution when connecting this circuit. Do not apply +12VDC directly to J3-10. This will result in damage to U2.

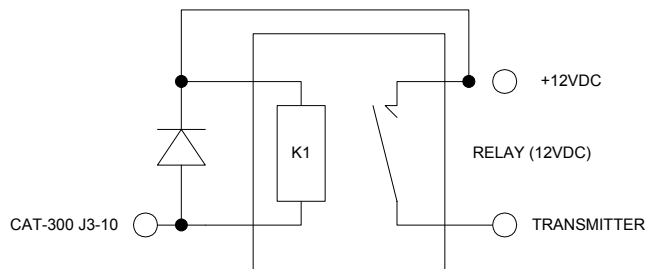
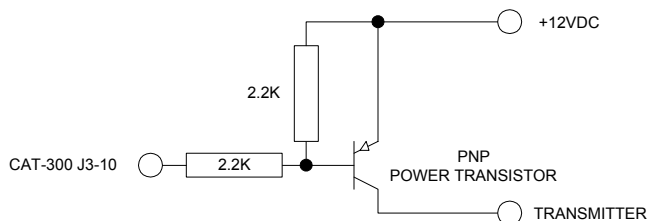

Figure 6-5

CAT-300 Remote Base Connection

Although the CAT-300 was not intended to operate a remote base, it is relatively easy to add a transceiver if the RX audios are mixed external to the CAT-300 and the TX audio output is shared between the two transmitters. When Zone 6 Channel 1 is enabled, Output #3 is converted to a transceiver PTT, while Input #1 becomes a transceiver COR input. Output #3 (PTT #2) will be active only when repeater COR is active. It will not be active when Input #1 (COR #2) is active. Both the repeater and transceiver must supply squelch switched audio.

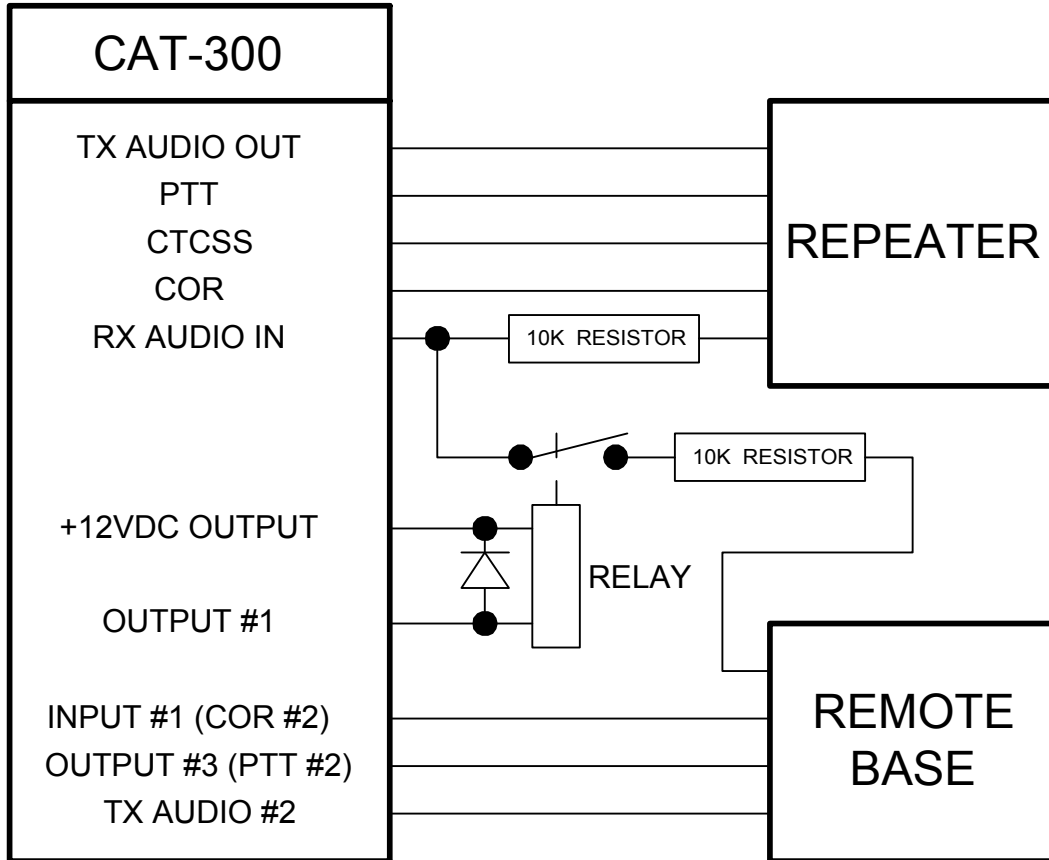

Figure 6-6

Chapter 7 - Voice Vocabulary

CAT-300 Word Listing

Zero.....	000	Area.....	235	D.....	310
One.....	001	As.....	236	Danger.....	311
Two.....	002	Assistance.....	237	Data.....	312
Three.....	003	Association.....	238	Date.....	313
Four.....	004	At.....	239	Day.....	314
Five.....	005	Attempt.....	240	Days.....	315
Six.....	006	Attention.....	241	December.....	316
Seven.....	007	August.....	242	Decrease.....	317
Eight.....	008	Automatic.....	243	Degree.....	318
Nine.....	009	Autopatch.....	244	Delay.....	319
Ten.....	010	Auxiliary.....	245	Delta.....	320
Eleven.....	011	Avenue.....	246	Department.....	321
Twelve.....	012	Average.....	247	Direction.....	322
Thirteen.....	013	B		Do.....	323
Fourteen.....	014	B.....	250	Down.....	324
Fifteen.....	015	Back.....	251	Drizzle.....	325
Sixteen.....	016	Band.....	252	Due.....	326
Seventeen.....	017	Base.....	253	Dynamic.....	327
Eighteen.....	018	Below.....	255	E	
Nineteen.....	019	Between.....	256	E.....	340
Twenty.....	020	Bravo.....	257	East.....	341
Thirty.....	030	Break.....	258	Echo.....	342
Forty.....	040	By.....	260	Ed (suffix).....	343
Fifty.....	050	C		Emergency.....	344
Sixty.....	060	C.....	270	End.....	345
Seventy.....	070	Calibrate.....	271	Enter.....	346
Eighty.....	080	Call.....	272	Equals.....	347
Ninety.....	090	Calling.....	273	Error.....	348
A		Cancel.....	274	Evacuation.....	349
A.....	210	Cat.....	275	Exit.....	350
A.M.....	211	Caution.....	276	Expect.....	351
Abort.....	212	Center.....	277	F	
Above.....	214	Celsius.....	278	F.....	370
Acknowledge.....	215	Change.....	279	Fail.....	371
Action.....	216	Charlie.....	280	Failure.....	372
Adjust.....	217	Check.....	281	Fahrenheit.....	373
Advise.....	218	Circuit.....	282	Fast.....	374
Affirmative.....	220	Clear.....	283	February.....	375
Again.....	221	Clock.....	284	Feet.....	376
Air.....	222	Closed.....	285	File.....	378
Alert.....	223	Club.....	286	Fire.....	381
All.....	224	Code.....	287	Fog.....	383
Alpha.....	225	Complete.....	289	For.....	384
Alternate.....	226	Completed.....	290	Foxhunt.....	385
Altitude.....	227	Computer.....	291	Foxtrot.....	386
Amateur.....	228	Condition.....	292	Freezing.....	387
Amps.....	229	Connect.....	294	Frequency.....	388
An.....	230	Contact.....	295	Friday.....	389
And.....	231	Control.....	296	From.....	390
Answer.....	232	Cycle.....	298	Full.....	392
April.....	233	D		G	
Are.....	234				

G..... 410
 Gear..... 411
 Get..... 412
 Go..... 413
 Golf..... 414
 Good..... 415
 Green..... 416
 Ground..... 417

H

H..... 440
 Hail..... 441
 Half..... 442
 Ham..... 443
 Hamfest..... 444
 Have..... 445
 Hazardous..... 446
 Henry..... 448
 Hertz..... 449
 High..... 450
 Hotel..... 453
 Hour..... 454
 Hours..... 455
 Hundred..... 456

I

I..... 470
 Ice..... 471
 Icing..... 472
 Identify..... 473
 Immediately..... 474
 In..... 475
 Increase..... 476
 India..... 477
 Information..... 478
 Ing (suffix)..... 479
 Inputs..... 480
 Intruder..... 481
 Is..... 482
 It..... 483

J

J..... 500
 January..... 501
 Juliet..... 502
 July..... 503
 June..... 504

K

K..... 530
 Key..... 531
 Keypad..... 532
 Kilo..... 533

L

L..... 550
 Last..... 552
 Left..... 554
 Less than..... 555
 Let..... 556
 Light..... 558
 Lima..... 559
 Line..... 560
 Link..... 561
 List..... 562

Load..... 563
 Lockout..... 565
 Low..... 568
 Lower..... 569

M

M..... 580
 Machine..... 581
 Macro..... 582
 Make..... 583
 Manual..... 585
 Many..... 586
 March..... 587
 May..... 588
 Measure..... 591
 Measured..... 592
 Meeting..... 593
 Mega..... 594
 Message..... 595
 Meter..... 596
 Meters..... 597
 Mike..... 599
 Miles..... 600
 Million..... 602
 Minus..... 603
 Minute..... 604
 Minutes..... 605
 Mobile..... 606
 Modified..... 607
 Monday..... 608
 Month..... 609
 More than..... 610
 Move..... 611
 Much..... 612

N

N..... 620
 Near..... 621
 Net..... 623
 New..... 624
 Next..... 625
 Night..... 626
 No..... 627
 Normal..... 628
 North..... 629
 Not..... 630
 November..... 631
 Now..... 632
 Number..... 633

O

O..... 650
 O'clock..... 651
 October..... 652
 Of..... 653
 Off..... 654
 Ohms..... 655
 On..... 656
 Open..... 657
 Operator..... 659
 Or..... 660
 Oscar..... 662
 Other..... 663
 Out..... 664

Over..... 665

P

P..... 680
 P.M..... 681
 Papa..... 682
 Patch..... 684
 Per..... 685
 Plan..... 688
 Please..... 689
 Plus..... 690
 Point..... 691
 Police..... 692
 Position..... 693
 Pound..... 694
 Power..... 695
 Prefix..... 696
 Preset..... 697
 Program..... 699
 Put..... 702

Q

Q..... 720
 Quebec..... 721

R

R..... 730
 Radio..... 731
 Radios..... 732
 Rain..... 733
 Range..... 735
 Rate..... 736
 Ready..... 737
 Receive..... 738
 Receiver..... 739
 Red..... 740
 Release..... 741
 Remark..... 742
 Remote..... 743
 Repair..... 744
 Repeat..... 745
 Repeater..... 746
 Reset..... 747
 Right..... 749
 Road..... 750
 Roger..... 751
 Romeo..... 752

S

S..... 770
 Safe..... 771
 Saturday..... 772
 Seconds..... 774
 Security..... 775
 Send..... 777
 Sent..... 778
 September..... 779
 Sequence..... 780
 Service..... 781
 Set..... 782
 Severe..... 783
 Short..... 784
 Showers..... 785
 Side..... 787
 Sierra..... 788

Slow..... 790
 Snow..... 791
 South..... 792
 Speed..... 793
 Star..... 795
 Start..... 796
 Stop..... 797
 Storm..... 798
 Sunday..... 799
 Switch..... 800
 System..... 801
 S (plural)..... 802

T

T..... 820
 Tango..... 821
 Telephone..... 823
 Temperature..... 824
 Test..... 826
 Than..... 827
 Thank-You..... 828
 That..... 829
 The (shortE)..... 830
 The (longE)..... 831
 Then..... 832
 This..... 833
 This-is..... 834
 Thousand..... 835
 Thunderstorms..... 836
 Thursday..... 837
 Time..... 838
 Timer..... 839
 Today..... 840
 Tomorrow..... 841
 Tonight..... 842
 Tornado..... 843
 Tower..... 844
 Traffic..... 845
 Transmit..... 846
 Transmitter..... 847
 Try..... 848
 Tuesday..... 849
 Turn..... 850
 Type..... 851

U

U..... 870
 Uniform..... 871
 Unit..... 872
 Until..... 874
 Up..... 875
 Use (noun)..... 876
 Use (verb)..... 877

V

V..... 880
 Verify..... 882
 Version..... 883
 Victor..... 884
 Volts..... 885

W

W..... 890
 Wait..... 891
 Warning..... 892

Watch..... 893
 Watts..... 894
 Weather..... 896
 Wednesday..... 897
 Week..... 898
 Weekday..... 899
 Welcome..... 900
 West..... 902
 What..... 903
 Whiskey..... 904
 Will..... 905
 Wind..... 906
 With..... 908

X

X..... 920
 X-Ray..... 921

Y

Y..... 930
 Yankee..... 931
 Year..... 932
 Yellow..... 933
 Yes..... 934
 Yesterday..... 935
 You..... 936
 Your..... 937

Z

Z..... 950
 Zed..... 951
 Zero..... 952
 Zone..... 953
 Zulu..... 954

Pause 1..... 960
 Pause 2..... 961
 Pause 3..... 962
 Pause 4..... 963

Sound Effects

Chime 1..... 964
 Chime 2..... 965
 Chime 3..... 966
 Gunshot..... 967
 Laughter..... 972

Female

Good Morning..... 980
 Good Afternoon... 981
 Good Evening..... 982

Time Variables

Time of Day..... 100*
 Day of Week..... 101*
 Day and Month.... 102*
 Salutation..... 103*

User Function Control

UF #1 OFF..... 111
 UF #1 ON..... 112
 UF #1 MON..... 113
 UF #2 OFF..... 114
 UF #2 ON..... 115

UF #2 MON..... 116
 UF #3 OFF..... 117
 UF #3 ON..... 118
 UF #3 MON..... 119
 500 mSEC Delay... 135

DVR Tracks

Track #1..... 140
 Track #2..... 141
 Track #3..... 142
 Track #4..... 143
 Track #5..... 144
 Track #6..... 145
 Track #7..... 146
 Track #8..... 147
 Track #9..... 148
 Track #10..... 149
 Track #11..... 150
 Track #12..... 151
 Track #13..... 152
 Track #14..... 153
 Track #15..... 154
 Track #16..... 155

Courtesy Tones

Tone #1..... 161
 Tone #2..... 162
 Tone #3..... 163
 Tone #4..... 164
 Tone #5..... 165
 Tone #6..... 166
 Tone #7..... 167
 Tone #8..... 168

* CAT-300 [DX] ONLY

Chapter 8 - Diagrams

CAT-300 Repeater Controller

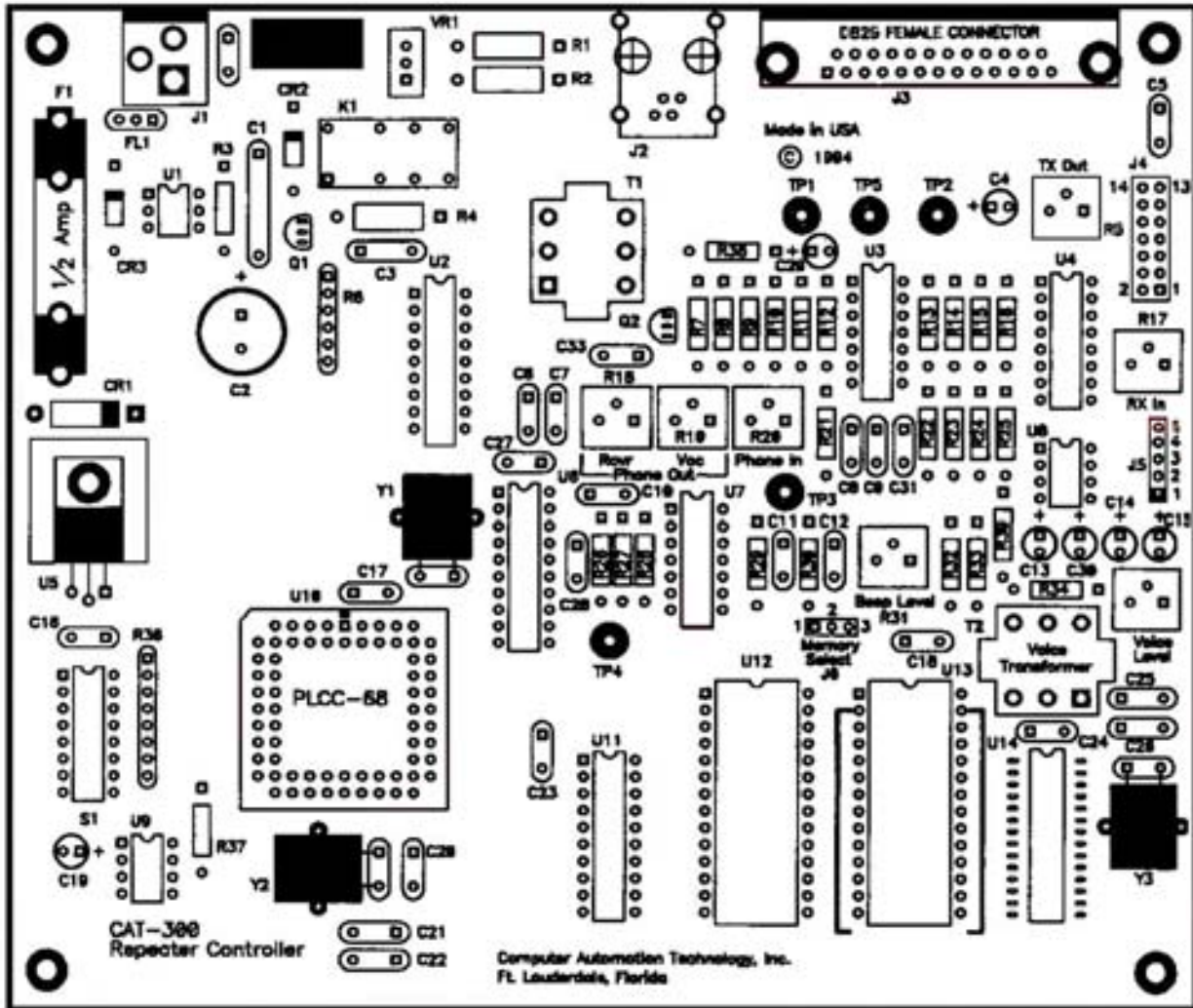

CI-300 Computer Interface

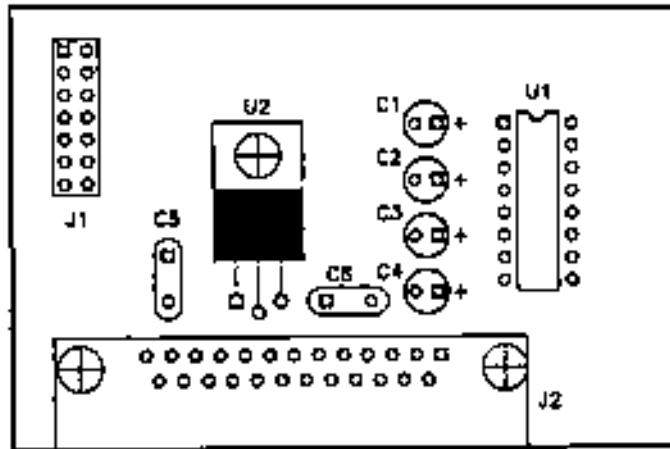

DL-1000C Digital Audio Delay

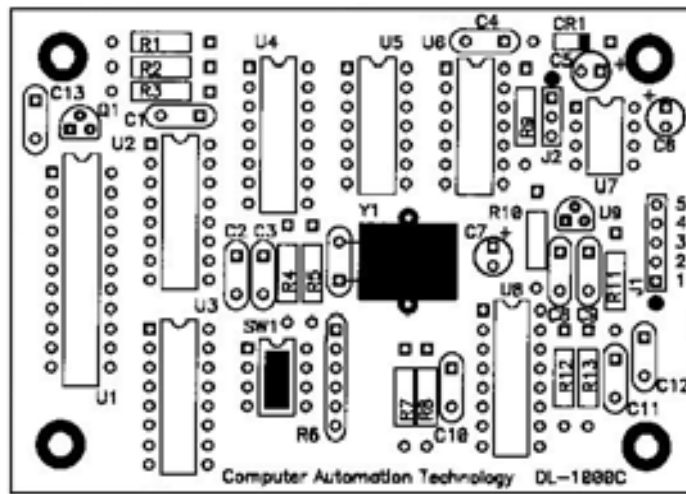

DR-1000 Digital Voice Recorder

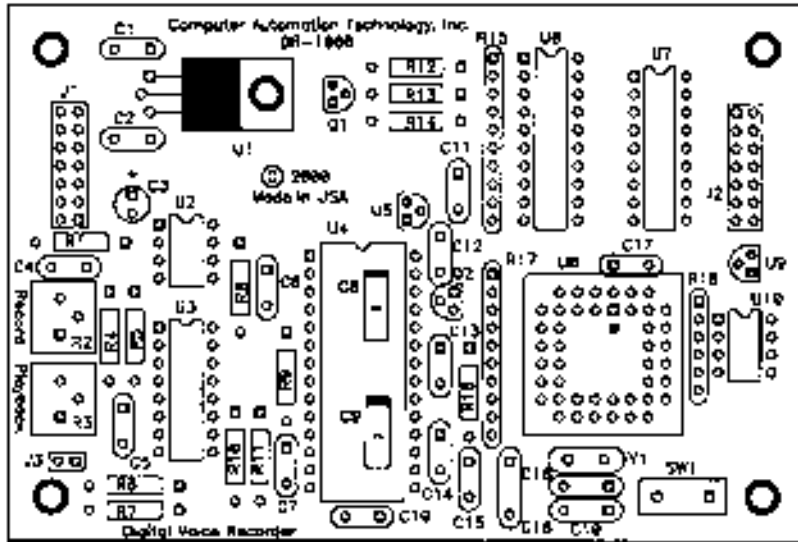

Chapter 9 - Schematics

11-2	Controller Board (CAT-300)	sheet 1 of 1
11-3	Computer Interface (CI-300)	sheet 1 of 1
11-4	Audio Delay (DL-1000C)	sheet 1 of 1
11-5	Digital Recorder (DR-1000)	sheet 1 of 1

Chapter 10 - Parts List

CAT-300 Controller

2	Capacitor	12pF 100VDC	C21,C22
2	Capacitor	33pF 100VDC	C25,C26
1	Capacitor	0.47uF 250VDC	C1
1	Capacitor	1.0uF 50VDC	C3
1	Capacitor	470uF 25VDC	C2
2	Capacitor	.001uF 50VDC	C8,C33
4	Capacitor	.015uF 50VDC	C9,C11,C12,C28
0	Capacitor	User Select	C31
7	Capacitor	10 uF 16VDC	C4,C13,C14,C15,C19,C29,C30
12	Capacitor	0.1uF 50VDC	C5,C6,C7,C10,C16,C17,C18, C20,C23,C24,C27,C32
1	Crystal	3.58 MHz	Y1
1	Crystal	12.0 MHz	Y2
1	Crystal	3.27 MHz	Y3
1	Connector	Phone Jack	J2
1	Connector	DC Power 2.5mm	J1
1	Connector	"D" 25pin Female	J3
1	Connector	Header 2X7	J4
1	Connector	Header 1X3	J6
1	Connector	Header 1X5	J5
2	Diode	1N4005	CR2,CR3
1	Filter	Low Pass	FL1
1	I.C.	4N26	U1
1	I.C.	ULN2803A	U2
1	I.C.	LM348	U3
1	I.C.	MC4053	U4
1	I.C.	LM340T-5	U5
1	I.C.	MT8880	U6
1	I.C.	74HCT10	U7
1	I.C.	ICL7660	U8
1	I.C.	DS1232	U9
1	I.C.	80C535	U10
1	I.C.	74HCT573	U11
1	I.C.	27C512	U12
1	I.C.	DS1220Y/DS1243Y	U13
1	I.C.	TSP53C30	U14
1	Fuse	0.5A	F1
2	Jumper		JP5,JP6
1	Relay	DPDT 12V	K1
2	Resistor	10 0.5W	R1,R2
2	Resistor	22K 0.25W	R3,R15
1	Resistor	470 0.5W	R4
1	Resistor	620 0.25W	R7
3	Resistor	2.2K 0.25W	R8,R9,R32
3	Resistor	100K 0.25W	R10,R12,R26
1	Resistor	560K 0.25W	R28
4	Resistor	33K 0.25W	R16,R22,R29,R30
8	Resistor	10K 0.25W	R11,R14,R23,R24
1	Resistor	47K 0.25W	R13
2	Resistor	18K 0.25W	R21,R33
2	Resistor	100 0.25W	R38,R39
5	Resistor	10K Variable	R17,R18,R19,R20,R31
2	Resistor	5K Variable	R5,R35
1	Resistor	10K Network	R36
1	Resistor	4.7K Network	R6
1	Sidactor	P2353AB	VR1
1	Switch	8 Position (DIP)	S1
2	Transformer	600:600 ohm CT	T1,T2

2	Transistor	VN10KM	Q1,Q2
1	Transorb	1N6278A	CR1
5	Test Point		TP1,TP2,TP3,TP4,TP5

CI-300 Computer Interface

4	Capacitor	10uF 16V	C1,C2,C3,C4
2	Capacitor	0.1uF 50V	C5,C6
1	Connector	Header 2X7	J1
1	Connector	DB-25F	J2
1	I.C.	MAX232	U1
1	I.C.	LM340T-5	U2

DL-1000C Audio Delay Board

7	Capacitor	0.1uF 50V	C1,C4,C8,C9,C10,C11,C12
3	Capacitor	10uF 16V	C5,C6,C7
2	Capacitor	18pF 50V	C2,C3
1	Capacitor	.001uF 50V	C13
1	Crystal	2.048Mhz	Y1
1	Diode	1N4148	CR1
1	Header	1X3	J2
1	Header	1X4	J1
1	I.C.	74HC73	U5
1	I.C.	74HC02	U6
2	I.C.	74HC4520	U2,U3
1	I.C.	CY7C187	U1
1	I.C.	MC7805AC	U9
1	I.C.	74HC4060	U4
1	I.C.	TP3054	U8
1	I.C.	7660CPA	U7
3	Resistor	10K 5% 1/4W	R1,R3,R11
1	Resistor	4.7K 5% 1/4W	R9
1	Resistor	22K 5% 1/4W	R13
1	Resistor	100 5% 1/4W	R10
2	Resistor	47K 5% 1/4W	R2,R12
3	Resistor	330 5% 1/4W	R4,R7,R8
1	Resistor	10MEG 5% 1/4W	R5
1	Resistor	10K 6pin Network	R6
1	Switch	Dip 4 Pole	SW1
1	Transistor	VN10KM	Q1

DR-1000 Digital Voice Recorder Board

1	Capacitor	1.0uF 50V	C16
1	Capacitor	10uF 16V	C3
2	Capacitor	10uF (SM)	C8,C9
2	Capacitor	33PF 50V	C18,C19
2	Capacitor	.001uF 50V	C6,C13
2	Capacitor	.22uF 50V	C12,C14
8	Capacitor	0.1uF 50V	C1,C2,C4,C5,C7,C10,C11,C15
1	Crystal	12MHz	Y1
2	Header	2X7	J1,J2
1	Header	1X2	J3
1	I.C.	ISD 4003-04MP	U4
1	I.C.	74HC540	U6
1	I.C.	LT1121CZ-3.3	U5
1	I.C.	MC4053	U3
1	I.C.	MCP101-485	U9
1	I.C.	AT89C51-12JC	U8
1	I.C.	NM25C040	U10
1	I.C.	LM340-5	U1
1	I.C.	TLC2272CP	U2
1	I.C.	ULN2804A	U7
1	Resistor	330 5% 1/4W	R12
1	Resistor	3.9 K5% 1/4W	R13
4	Resistor	10K 5% 1/4W	R1,R6,R7,R10
2	Resistor	33K 5% 1/4W	R4,R9
1	Resistor	82K 5% 1/4W	R5
4	Resistor	100K 5% 1/4W	R8,R11,R14,R16
2	Resistor	10K 10pin	R15,R17
1	Resistor	10K 6pin	R18
2	Resistor	10K Variable	R2,R3
1	Switch	Push-Button	SW1
1	Transistor	2N3906	Q1
1	Transistor	2N3904	Q2

Chapter 11 - Computer Interface

CI-300 Computer Interface

When the CI-300 is connected to the accessory header J4, a 4800-baud RS-232

port is added to the CAT-300DX controller. The entire contents of RAM memory can be down loaded and stored on disk. An optional editor program can be used to display, print or change the CAT-300DX memory. Once changed, the memory can be up loaded to the CAT-300DX using the CI-300.

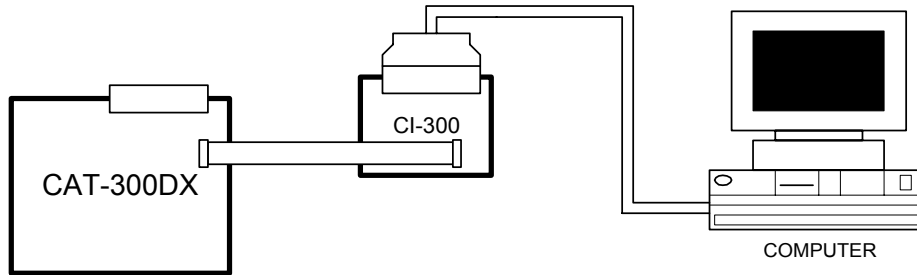

Figure 11-1

Computer Serial Port Configuration

Use the CAT COMM program included on the editor disks to communicate with the CAT-300DX. If necessary, click on the configuration button to configure the serial port for 4800 baud, 8 data bits, N parity and 1 stop bit. The data file name must include the file extension **.300**. A typical valid file name would be **W4XYZ.300** or **01MAR95.300**. The example that follows, describes how to communicate with the CAT-300DX using the CAT COMM program.

Activation Of The Computer Interface

In addition to programming a new unlock-number, dipswitch 8 is used to activate the computer interface. Turn the DC power off. Set dipswitch 8 to ON and turn the DC power on. After the power up message is complete, the CAT-300DX will switch to the computer interface mode.

Remote Activation Of The Computer Interface

Key-up and enter the control operator prefix code followed by **[97]**. Un-key and the CAT-300DX will automatically switch to the computer interface mode. When the computer interface activates the computer will display:

Please press (ENTER) to begin.

Press the ENTER key and the computer will display:

CAT-300 Data Transfer. D=Download...U=Upload...Q=Quit. Select >

To **DOWNLOAD** the memory and save it to disk, Type: **d (ENTER)**. The CAT-300DX will send the memory using X-modem protocol. Select the download transfer function on your computer by clicking on the **DOWNLOAD** button. Once the download sequence starts, monitor the activity display of packets transferred until the download is complete.

To **UPLOAD** the memory from the computer to the CAT-300DX, Type: **u** (**ENTER**). The CAT-300DX will receive the memory using X-modem protocol. Select the upload transfer function on your computer by clicking on the UPLOAD button. Once the upload sequence starts, monitor the activity display of packets transferred, until the upload is complete.

To **QUIT** the computer interface Type: **q**

To **EXIT** the CAT COMM program click on File Exit Program.

CAT-300DX Windows Editor

The CAT Windows Editor offers a monumental break through in repeater controller programming. No endless string of DTMF tones to enter or confusing script files to write. Completely mouse driven, just point and click.

Voice Messages

From the voice message display window, place the hand on the message cell and double click. The voice synthesizer editor dialogue box window will appear. From the voice message display window, place the hand on the message cell and double click. The voice synthesizer editor dialogue box window will appear. Double click the letters, words and numbers in the voice word table.

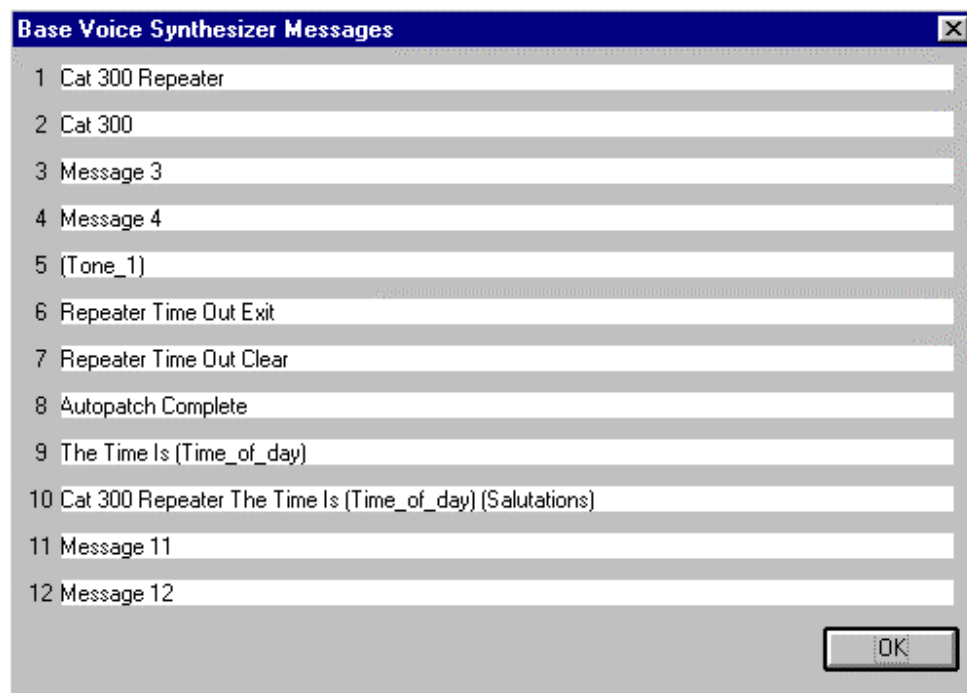

Figure 11-2

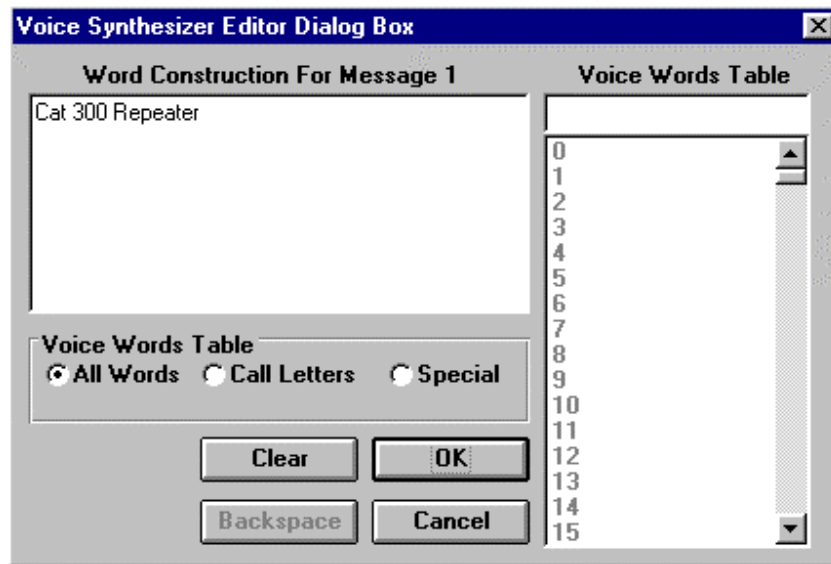

Figure 11-3

Print Driver

The CAT-300DX Windows Editor Program includes a print driver to produce a hard copy of the data in the controller's memory. Use the printed material to prepare manuals for the system control operators. From the print driver window select from the following print command boxes:

Repeater Codes	Repeater Timers	Voice Messages	Control Zones
Memory Saves 1-4	Macros	Scheduler	Speed Dials
Courtesy Tones	CW Messages	Telephone Prefix	Area Codes

User Speed Dial

To program a speed dial window, place the hand on the telephone number cell and double click. The keypad window will appear. Use the keypad to enter the telephone number and click OK. Place the hand on the identification cell and double click. The voice synthesizer editor box window will appear. Double click the letters, words and numbers in the voice word table.

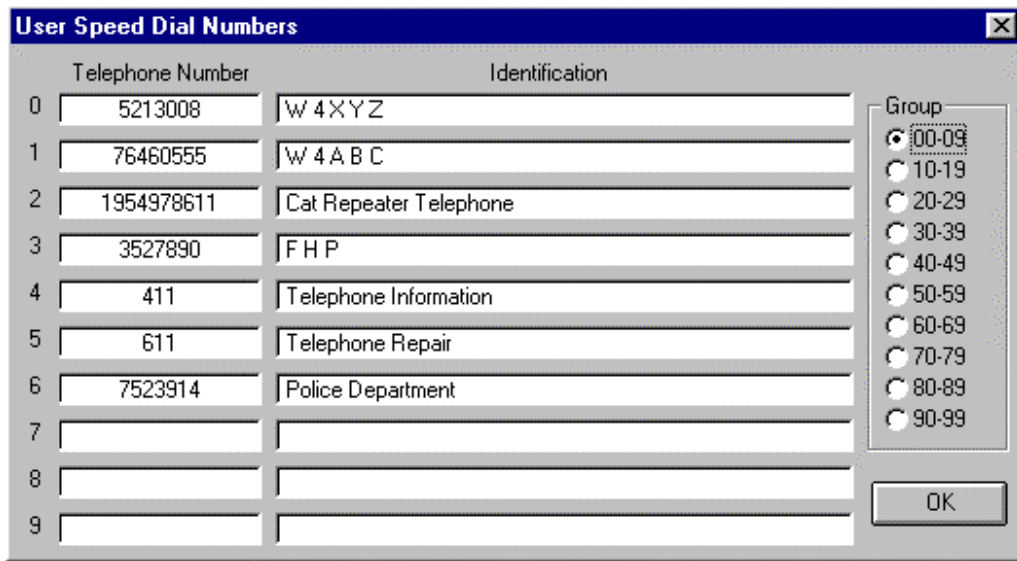

Figure 11-4

Emergency Speed Dial

To program an emergency speed dial location, use the emergency speed dial window.

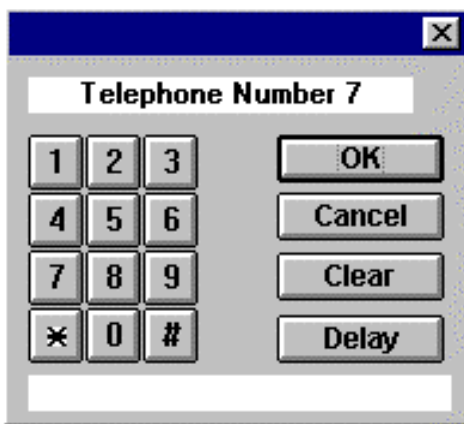

Figure 11-5

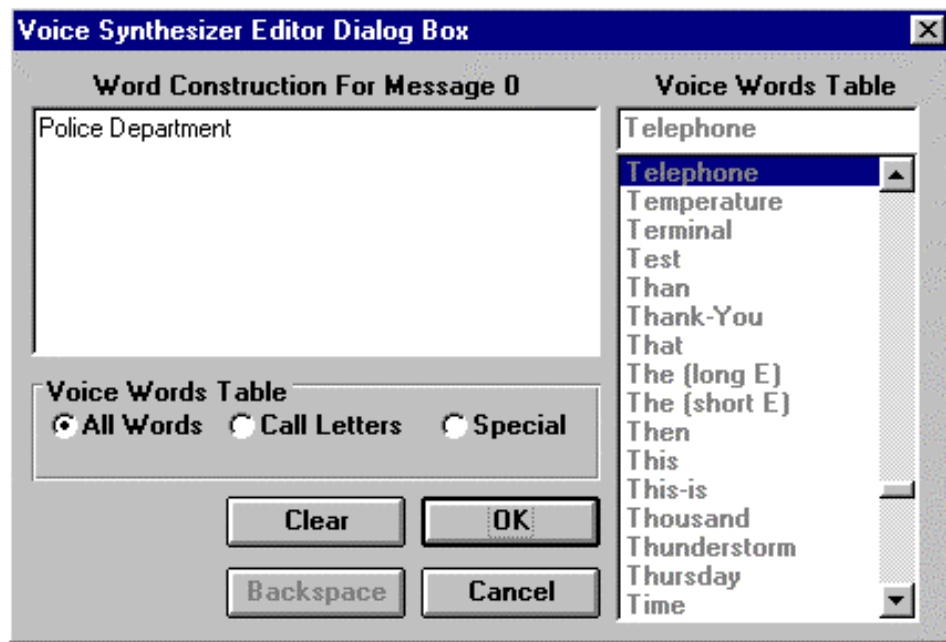

Figure 11-6

Control Zones

From the zone window, place the arrow on the ZONE TAB of interest and click. The selected zone card will move to the front of the window and the enabled channels in that zone will appear with a check mark in the boxes. To change the status of a control channel in the zone, place the arrow in the desired box and click.

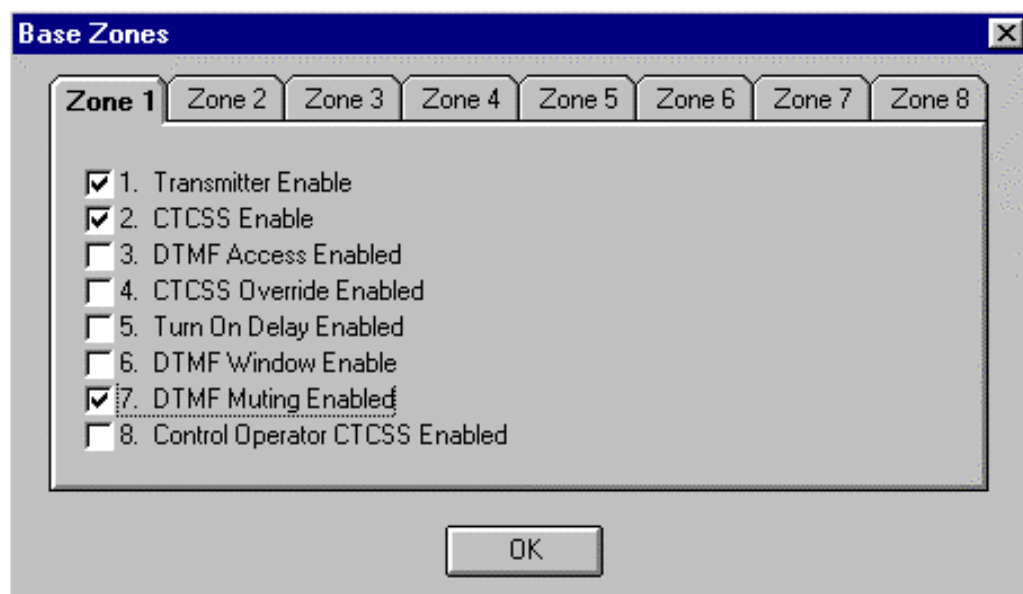

Figure 11-7

Scheduler

From the scheduler window, place the hand on the TIME cell and double click. The SCHEDULER POSITION window will appear. Place the hand on the COMMAND cell and double click. The KEYPAD window will appear. Use the keypad to enter the COMMAND and click OK. Place the hand on the SCHEDULED TIME cell and double click. Use the keypad to enter the time and click OK.

The screenshot shows the 'CAT-300 Scheduler' window. At the top, there is a 'Scheduler Group' section with four radio buttons: '1-10' (selected), '11-20', '21-30', and '31-40'. An 'OK' button is to the right. Below this is a table with 10 rows and 5 columns: 'Time', 'Day Of Week', 'Month/Day Of Year', and 'Cmd'. The data in the table is as follows:

	Time	Day Of Week	Month/Day Of Year	Cmd
1	07:00	Weekdays	Skip	1411
2	23:00	Weekdays	Skip	1410
3	06:30	Daily	Skip	1331
4	15:30	Daily	Skip	1330
5	----:50	Daily	Skip	3012
6	08:00	----	July 4	5002
7				
8				
9				
10				

Figure 11-8

The screenshot shows the 'Scheduler Position 6' window. It has a 'Scheduled Event' section with four radio buttons: 'Daily' (selected), 'Weekdays Only', 'Weekends Only', and 'Select Weekday'. Below this is a 'Select Month / Day' section with a dropdown menu set to 'July' and a numeric spinner set to '4'. There are two input fields: 'Command' containing '5002' and 'Command Review' containing 'Execute Macro 2'. At the bottom, there is a 'Scheduled Time' section with a spinner set to '0800' and an 'Every Hour' checkbox. An 'Erase(d) Location' checkbox is also present and unchecked. An 'OK' button is at the bottom right.

Figure 11-9

Control Codes

From the repeater code window, place the hand on the CONTROL OPERATOR PREFIX cell and double click. The KEYPAD window will appear. Use the key pad to enter a new control operator prefix code and click OK.

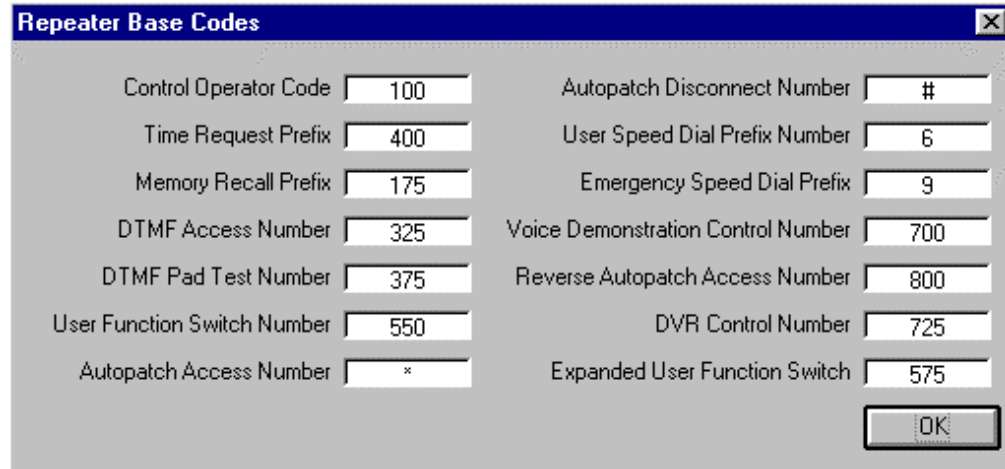

The screenshot shows a dialog box titled "Repeater Base Codes" with a close button (X) in the top right corner. The dialog contains two columns of input fields, each with a label and a text box. The fields are:

Control Operator Code	100	Autopatch Disconnect Number	#
Time Request Prefix	400	User Speed Dial Prefix Number	6
Memory Recall Prefix	175	Emergency Speed Dial Prefix	9
DTMF Access Number	325	Voice Demonstration Control Number	700
DTMF Pad Test Number	375	Reverse Autopatch Access Number	800
User Function Switch Number	550	DVR Control Number	725
Autopatch Access Number	*	Expanded User Function Switch	575

An "OK" button is located at the bottom right of the dialog.

Figure 11-10

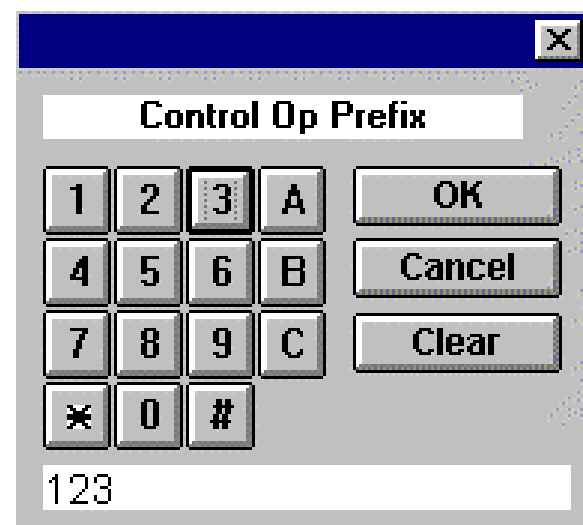

The screenshot shows a keypad dialog box titled "Control Op Prefix" with a close button (X) in the top right corner. The keypad consists of a 4x4 grid of buttons:

1	2	3	A
4	5	6	B
7	8	9	C
* (star)	0	#	

To the right of the keypad are three buttons: "OK", "Cancel", and "Clear". Below the keypad is a text input field containing the number "123".

Figure 11-11

Chapter 12 - DL-1000C Audio Delay Board

When placed in the receive audio path, the DL-1000C will eliminate the first chirp of DTMF tone during muting and the squelch crash noise present on many repeater systems. A dipswitch selects delays of 50, 100, 200 or 400 milliseconds. The delayed audio is faithfully reproduced.

Remove the jumper plug from the CAT-300 at J5. Connect the cable from the DL-1000C to header connector J5 to delay repeater audio.

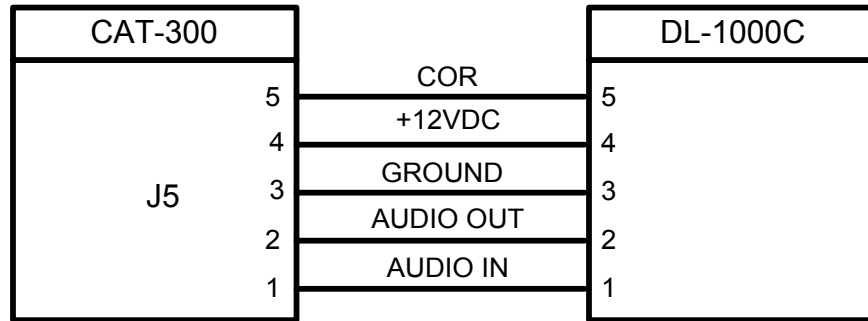

Figure 12-1

Select Delay

The amount of delay is determined by the setting of dipswitch. The typical repeater receiver has a squelch crash noise of 40 milliseconds. The 100 millisecond setting should be sufficient to eliminate the noise. If not increase the delay to the next setting. See Figure 12-2.

MILLISECONDS	SW1	SW1	SW1	SW1
0.0	OFF	OFF	OFF	OFF
50	ON	OFF	OFF	OFF
100	ON	ON	OFF	OFF
200	ON	ON	ON	OFF
400	ON	ON	ON	ON

Figure 12-2

The DL-1000B is inserted in the receive audio path before the controller's audio switch. This audio switch is controlled by the COR logic signal. Loss of COR will cause the audio switch to open, preventing the receive audio from reaching the transmitter. The DL-1000C provides time for the switch to open before the squelch crash noise reaches the switch's input.

During DTMF muting, 40 milliseconds of the first tone will sneak through before the DTMF decoder can tell the microprocessor to open the audio switch. The DL-1000B provides the necessary delay to overcome this problem.

Discriminator Switch

The DL-1000C can be used with discriminator audio. A FET switch Q1 is included on the board. If the repeater's COR logic is connected to the J1 header, the white noise hiss will be eliminated during key-up. If the COR logic is active high set the J2 jumper between pins 1 and 2. If the COR is active low set the J2 jumper between pins 2 and 3.

Chapter 13 - Digital Voice Recorder

The DR-1000 provides true voice message announcements on your repeater system. Substitute digital recorder tracks for voice messages, speed dial identifications and courtesy tones. With four minutes of total record time, sixteen audio tracks provide sufficient message capacity. Eight expanded user function switches are also included.

Connect the cable to the CAT-300 at J4. See Figure 13-1 below. Apply power to the controller.

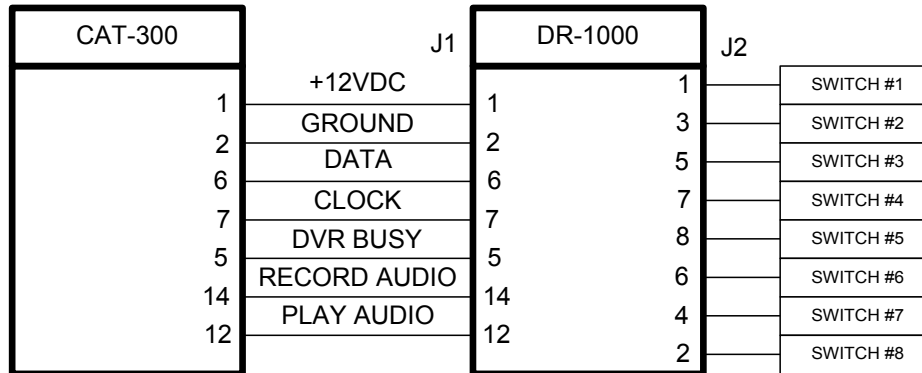

DR-1000 Interface
Figure 13-1

Format Digital Recorder Memory

Memory is protected during power failures. To format the DR-1000, press the Format switch SW1 located on the DR-1000 card.

Signal Report Test

Key-up and send the Signal Report code [725]. Un-key and the voice will say: "START TEST NOW." Key-up and record a seven second message. Un-key and the test message will play back. You instantly know how your signal sounds through the repeater.

Track length

The DR-1000 consists of sixteen tracks of fixed lengths. To conserve memory, select a track that matches the length of the recording.

Track Length Time			
Track #1	30 seconds	Track #9	10 Seconds
Track #2	30 seconds	Track #10	10 Seconds
Track #3	30 seconds	Track #11	6 Seconds
Track #4	30 seconds	Track #12	6 Seconds
Track #5	15 seconds	Track #13	6 Seconds
Track #6	15 seconds	Track #14	6 Seconds
Track #7	10 seconds	Track #15	6 Seconds
Track #8	10 seconds	Track #16	6 Seconds

Record Tracks By Radio (01-16)

The CAT-300 must be in the programming mode to record DR tracks. Key-up and enter the seven digit unlock code. Once unlocked, key-up and send [*95XX]. Un-key and the voice will say: "START MESSAGE". Key-up and enter the message to be stored at track "XX". Un-key and the voice will say: "CONTROL OK". To review the message, key-up and send [*94XX]. Un-key and the CAT-300 will play the message stored at track "XX". To erase a message, key-up and send [*96XX]. Un-key and the voice will say: "CONTROL OK". Tracks can be recorded, played or erased in any order. Total record time is two minutes. Maximum track length is thirty seconds. The DR-1000 cannot be used in a mailbox type application. It can only be used for announcement type messages.

Record Tracks By Telephone (01-16)

Call the repeater by telephone. The CAT-300 will answer and send a beep. Enter the seven digit unlock code followed by the [#]. Once unlocked, enter [*95XX#]. The voice will say: "START MESSAGE" and the record function will start. Speak into the phone to record the message. To stop the recording, press the [#]. Press and release the [#] key quickly. The DVR is programmed to automatically back-up and erase the [#] tone from the end of the message. The voice will say: "CONTROL OK". To review the message, enter [*94XX#]. Un-key and the CAT-300 will play the message stored at track "XX" over the telephone. The CAT-300 will play the message over the transmitter. To erase a message, enter [*96XX#]. The voice will say: "CONTROL OK".

Audio Level Adjustment

Set the RECORD level control R2 and the PLAYBACK level control R3 to mid-range. This set the audio path through the DVR at approximately unity gain. Use R2 and R3 to adjust the audio levels as desired. Measure the TX1 audio level at TP6 on the CAT-300. Adjust R3 so the playback audio at TP6 is the same level as the audio of the original signal.

Expanded User Function Switches

The eight expanded user function switches are open collector relay drivers. Each driver can sink up to 80ma and switch 40 VDC. Use the expanded user function switch prefix control [575] to set the switch pattern to the settings stored in the expanded user function switch table. Place diodes across the relay coils to protect the driver from negative spikes produced when the relay coil collapses.